

FILTRATION



T. Balakrishna M.Pharm
Assistant professor

Chebrolu Hanumaiah Institute of Pharmaceutical
Sciences

Chowdavaram, Guntur-522019.

DEFINITION

- Filtration: It may be define as a process of separation of solids from a fluid by passing the same through a porous medium that retains the solids but allows the fluid to pass through.
- Clarification: When solid are present in very low concentration, i.e., not exceeding 1.0% w/v, the process of its separation from liquid is called clarification.



TERMS USED IN FILTRATION

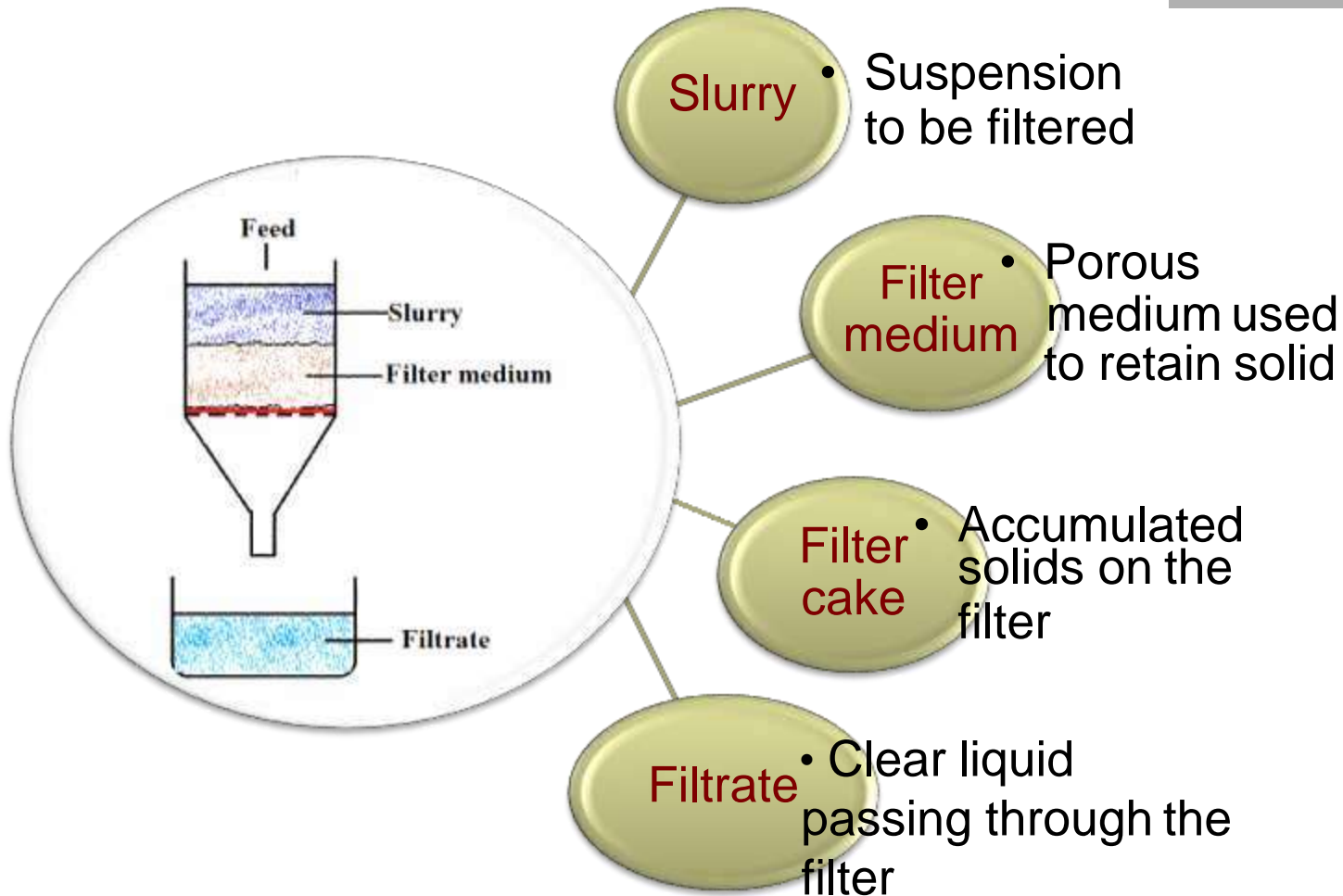

PROCESS OF FILTRATION

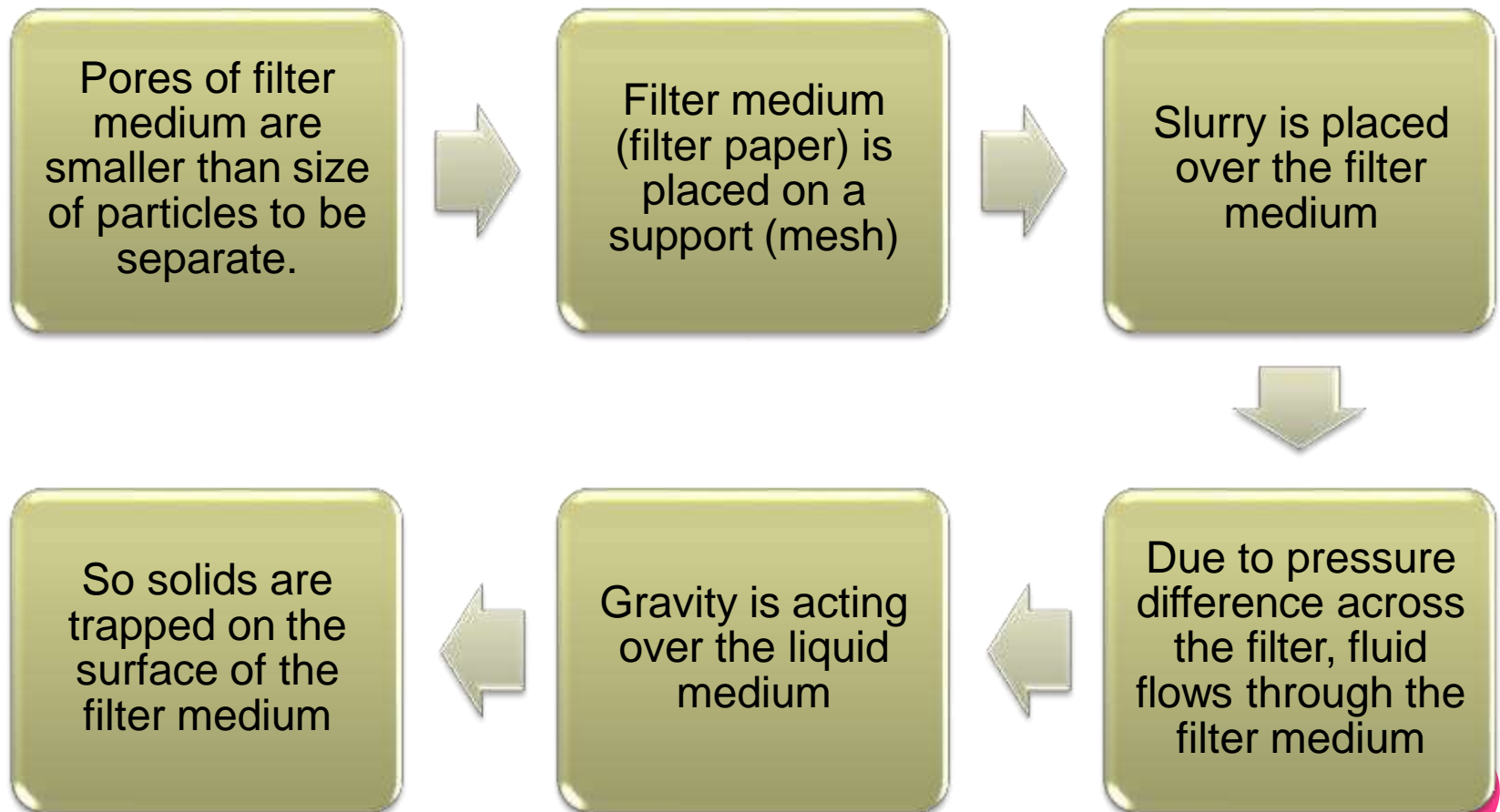

APPLICATIONS OF FILTRATION

- Production of sterile products:
 - ✓ HEPA filters or laminar air bench
 - ✓ Membrane filters.
- Production of bulk drugs
- Production of liquid dosage
- Effluents and waste water treatment



MECHANISM OF FILTRATION

- The mechanism whereby particles are retained by a filter is significant only in initial stages of filtration.

Straining

- Similar to sieving, i.e., particles of larger size can't pass through smaller pore size of filter medium.

Impingement

- Solids having the momentum move along the path of streaming flow and strike (impinge) the filter medium. Thus the solids are retained on the filter medium.

Entanglement

- Particles become entwined (entangled) in the masses of fibres (of cloths with fine hairy surface or porous felt) due to smaller size of particles than the pore size. Thus solids are retained within filter medium.

Attractive forces

- Solids are retained on the filter medium as a result of attractive force between particles and filter medium, as in case of electrostatic filtration.

TYPES OF FILTRATION

■ Surface/ screen filtration

- It is a screening action by which pores or holes of medium prevent the passage of solids.
- Mechanism involved : straining and impingement
- For this, plates with holes or woven sieves are used.
- Efficacy is defined in terms of mean or maximum pore size.

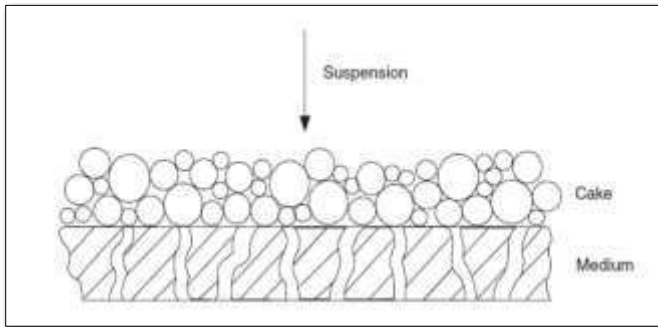

■ Depth filtration

- In this slurry penetrates to a point where the diameter of solid particles is greater than that of the tortuous void or channel.
- Mechanism : Entanglement
- The solids are retained with a gradient density structure by physical restriction or by adsorption properties of medium.

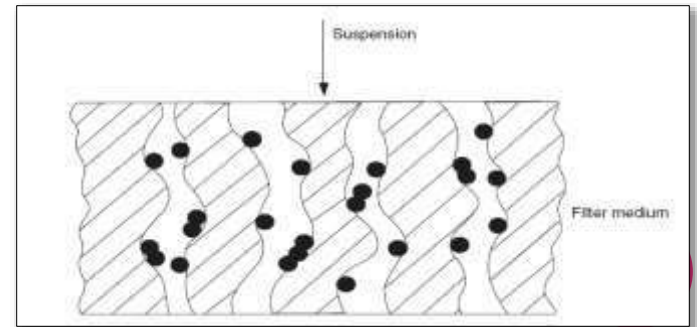

DIFFERENCE BETWEEN SURFACE AND DEPTH FILTRATION

○ Surface filtration

- The size of particles retained is slightly higher than the mean pore size of medium.
- Mechanical strength of filter medium is less, unless it is made of stainless steel.
- It has low capacity.
- The size of particles retained is more predictable.
- Equipment is expensive because ancillary equipment such as edge clamps is required.
- Ex. Cellulose membrane filter.

Depth filtration

- The size of particles retained is much smaller than the mean pore size of medium.
- Mechanical strength of filter medium is high.
- It has high capacity.
- The size of particles retained is less predictable.
- Equipment is cheaper because ancillary equipment is not required.
- Ex. Ceramic filters and sintered filters.

THEORIES OF FILTRATION

- The flow of liquid through a filter follows the basic rules that govern the flow of any liquid through the medium offering resistance.
- The rate of flow may be expressed as-

$$\text{Rate} = \text{driving force} / \text{resistance}$$

- The rate of filtration may be expressed as volume (litres) per unit time (dv/dt).
- Driving force = pressure upstream – pressure downstream
- Resistance is not constant.
- It increases with an increase in the deposition of solids on the filter medium.
- Therefore filtration is not a steady state.



CONTINUE.....

- The rate of flow will be greatest at the beginning of filtration process, since the resistance is minimum.
- After forming of filter cake, its surface acts as filter medium and solids continuously deposit adding to thickness of the cake.

Powder or granule bed visualized as a bundle of capillaries

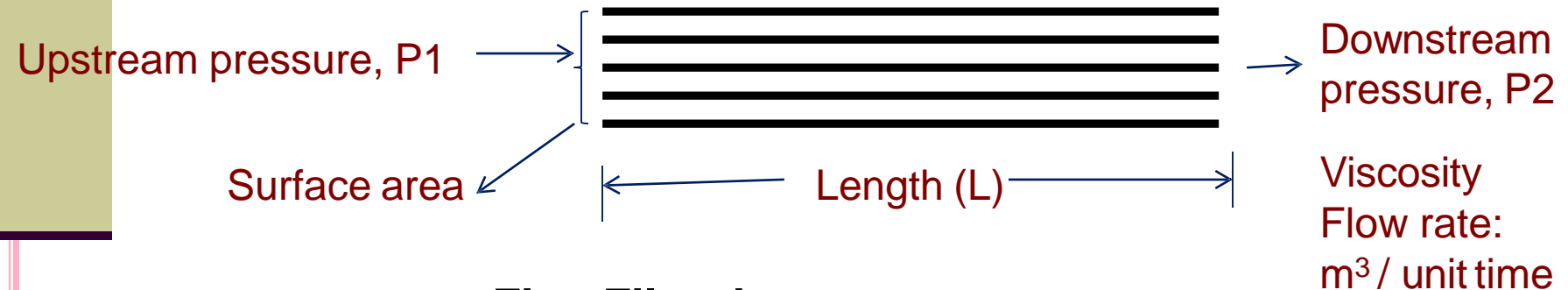

Fig.: Filtration process parameters.

- Resistance to flow is related to several factors given in fig.

Resistance to movement = {pressure upstream - pressure downstream} / length of capillaries

POISEULLIE'S EQUATION

- Poiseuille considered that filtration is similar to the streamline
- flow of liquid under pressure through capillaries.
- Poiseuille's Equation is $V = \frac{\pi \Delta P r^4}{8L\eta}$

- Where, V = rate of flow, m^3/s (l/s)
 - ΔP = Pressure difference across the filter, Pa
 - r = radius of capillary in the filter bed, m
 - L = thickness of filter cake (capillary length), m



DARCY'S EQUATION

- Poiseuille's law assumes that the capillaries found in the filter are highly irregular and non-uniform.
- Therefore, if the length of capillary is taken as the thickness of bed, a correction factor for radius is applied so that the rate is closely approximated and simplified.
- The factors influencing the rate of filtration has been incorporated into an equation by Darcy, which is:

$$V = \frac{KA\Delta P}{\eta L}$$

- Where, K = permeability coefficient of cake, m²
A = surface area of porous bed (filter medium), m²

Other terms are same as previous equation

- K depends on characteristics of cake, such as porosity, specific surface area and compressibility.

CONTINUE

....

- Permeability may be defined quantitatively as the flow rate of a liquid of unit viscosity across a unit area of cake having unit thickness under a pressure gradient of unity.
- This equation is valid for liquids flowing through sand, glass beds and various porous media.
- This model is applied to filter beds or cakes and other types of depth filter.
- This equation is further modified by including characteristics of K by Kozeny-Carman.

KOZENY-CARMAN (K-C) EQUATION

- Kozeny-Carman equation is widely used for filtration.

$$V = \frac{A}{\eta S^2} \times \frac{\Delta P}{KL} \times \frac{\epsilon^3}{(1 - \epsilon)^2}$$

- Where,

ϵ = porosity of cake (bed)

S = specific surface area of particles comprising the cake m^2 / m^3

K = Kozeny constant (usually taken as 5)

Other terms are same as previous equations

- Limitations:

- It does not consider the fact that depth of granular bed is lesser than the actual path traversed by the fluid.
- The actual path is not same through out the bed, but it is sinuous or tortuous.

FACTORS INFLUENCING FILTRATION

Properties of solid

- Particle shape
- Particle size
- Particle charge
- Density
- Particle size distribution
- Rigidity or compressibility of solid under pressure
- Tendency of particle to flocculate or adhere together

Properties of liquids

- Density
- Viscosity
- corrosiveness

Properties of solid in slurry

- Rate of formation of filter cake especially in early stage of filtration

Objectives

- Whether the solid or liquid or both are to be collected

Temperature

- Temperature of suspension

SURFACE AREA OF FILTER MEDIUM

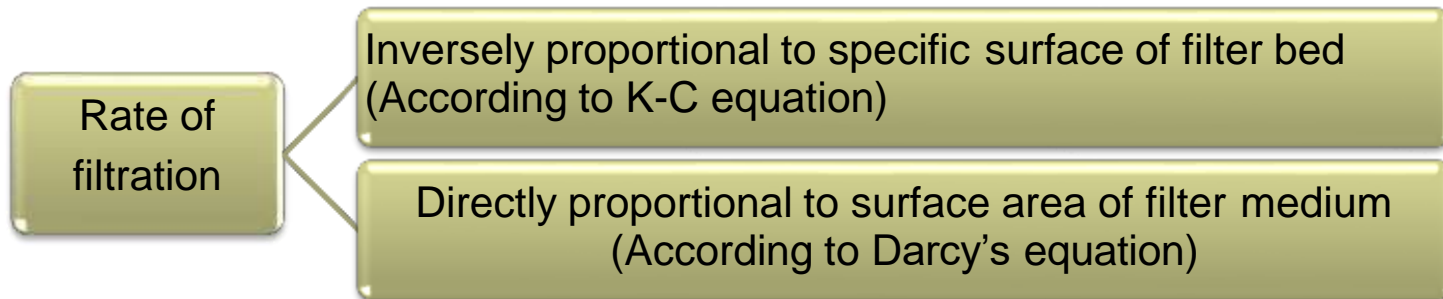

- Rate can be increased either using **large filter** or **connecting a number of small units in parallel**.
- Filter press works on principle of connecting units in parallel.

PRESSURE DROP ACROSS THE FILTER MEDIUM

- According to K-C equation the rate of filtration is proportional to the overall pressure drop across both the filter medium and filter cake.
- The pressure drop can be achieved in a number of ways:

Gravity

- A pressure difference could be obtained by maintaining a head of slurry above the filter medium.
- The pressure developed will depend on the density of the slurry

Vacuum
(Reducing pressure)

- The pressure below the filter medium may be reduced below atmospheric pressure by connecting the filtrate receiver to a vacuum pump and creating a pressure difference across the filter.

Pressure

- The simplest method being to pump the slurry into the filter under pressure.

Centrifugal force

- The gravitational force could be replaced by centrifugal force in particle separation

VISCOSITY OF FILTRATE

- According to K-C equation rate of filtration is **inversely proportional to the viscosity of the fluid**.
- Reason behind this is an increase in the viscosity of the filtrate will increase the resistance of flow.
- This problem can be overcome by two methods:
 - The rate of filtration may be increased by raising the temperature of the liquid, which lowers its viscosity. However, it is not practicable if thermolabile materials are involved or if the filtrate is volatile.
 - Dilution is another alternative but the rate must be doubled.

FILTER MEDIA

- The surface upon which solids are deposited in a filter is called the “Filter medium”
- Properties of ideal filter medium:
- **It should-**
 - 1) be capable of delivering a clear filtrate at a suitable production rate.
 - 2) have sufficient mechanical strength.
 - 3) be inert.
 - 4) retain the solids without plugging at the start of filtration.
 - 5) Not absorb dissolve material.
 - 6) Sterile filtration imposes a special requirement since the pore size must not exceed the dimension of bacteria or spores.

MATERIAL USED AS FILTER MEDIA

Woven material

- Made up of wool, silk, metal or synthetic fibres (rayon, nylon etc.).
- These include a- wire screening and b- fabrics of cotton, wool, nylon.
- Wire screening e.g. stainless steel is durable, resistance to plugging and easily cleaned.
- Cotton is a common filter ,however, Nylon is superior for pharmaceutical use, since it is unaffected by mold, fungus or bacteria and has negligible absorption properties .
- The choice of fibre depends on chemical

Perforated sheet metal

- Stainless steel plates have pores which act as channels as in case of meta filters.

Bed of granular solid built up on supporting medium

- In some processes, a bed of graded solids may be formed to reduce resistance of flow.
- Ex. Of granular solids are gravel, sand, asbestos, paper pulp and keiselgur.
- Choice of solids depends on size of solids in process.

PREFABRICATED POROUS SOLID UNITS

- Used for its convenience and effectiveness.
- Sintered glass, sintered metal, earthenware and porous plastics are used for fabrication.

Membrane filter media

- These are cartridge units and are economical and available in pore size of 100 μm to even less than 0.2 μm .
- Can be either surface cartridges or depth type cartridges.
- **Surface cartridges**
 - These are corrugated and resin treated papers and used in hydraulic lines.
 - Ceramic cartridges and porcelain filter candles are examples.
 - Can be reuse after cleaning.
- **Depth type cartridges:**
 - Made up of cotton, asbestos or cellulose.
 - These are disposable items, since cleaning is not feasible.



FILTER AIDS

- The objective of filter aid is to prevent the medium from becoming blocked and to form an open, porous cake, hence, reducing the resistance to flow of the filtrate.
- Filter aid forms a surface deposit which screens out the solids and also prevents the plugging of supporting filter medium.

Characteristics of filter aids:

- Chemically inert and free from impurities.
- Low specific gravity, so remain suspended in liquids.
- Porous rather than dense, so that pervious cake can be formed.
- Recoverable.

Disadvantages:

- Remove the coloured substances by absorbing them.
- Sometimes active principles such as alkaloids are absorbed on filter aid.
- Rarely, filters are source of contamination such as soluble iron salts, which can provoke degradation of sensitive ingredient.

HANDLING OF FILTER AIDS

- Filter aids may be used in either or both two ways:
 - 1) Pre- coating technique: by forming a pre-coat over the filter medium by filtering a suspension of the filter aid .
 - 2) Body- mix technique: A small proportion of the filter aid (0.1-0.5 %) is added to the slurry to be filtered. This slurry is recirculated through the filter until a clear filtrate is obtained, filtration then proceeds to completion.
- Different flow rates can be achieved depending on grade of aid-
 - 1.Low flow rate: fine grade filter aids- mainly used for clarity
 - 2.Fast flow rate: coarse grade filter aids- acceptable filtrate.

Examples of filter aids

- Diatomite (Keiselgur) , obtained from natural siliceous deposits.
- Perlite , it is an aluminium silicate. Cellulose, Asbestos, charcoal, talc, bentonite , fullers earth etc.

CLASSIFICATION OF FILTRATION EQUIPMENTS

- Based on application of external force:

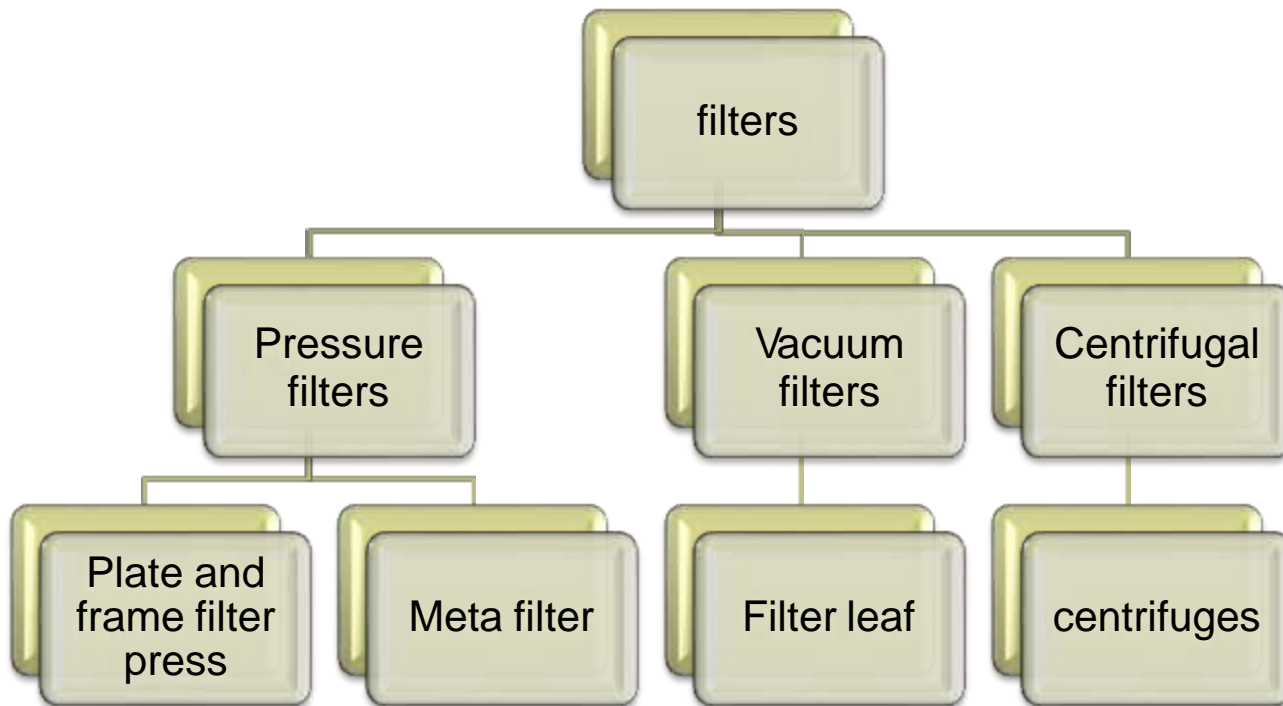

BASED ON OPERATION OF FILTRATION

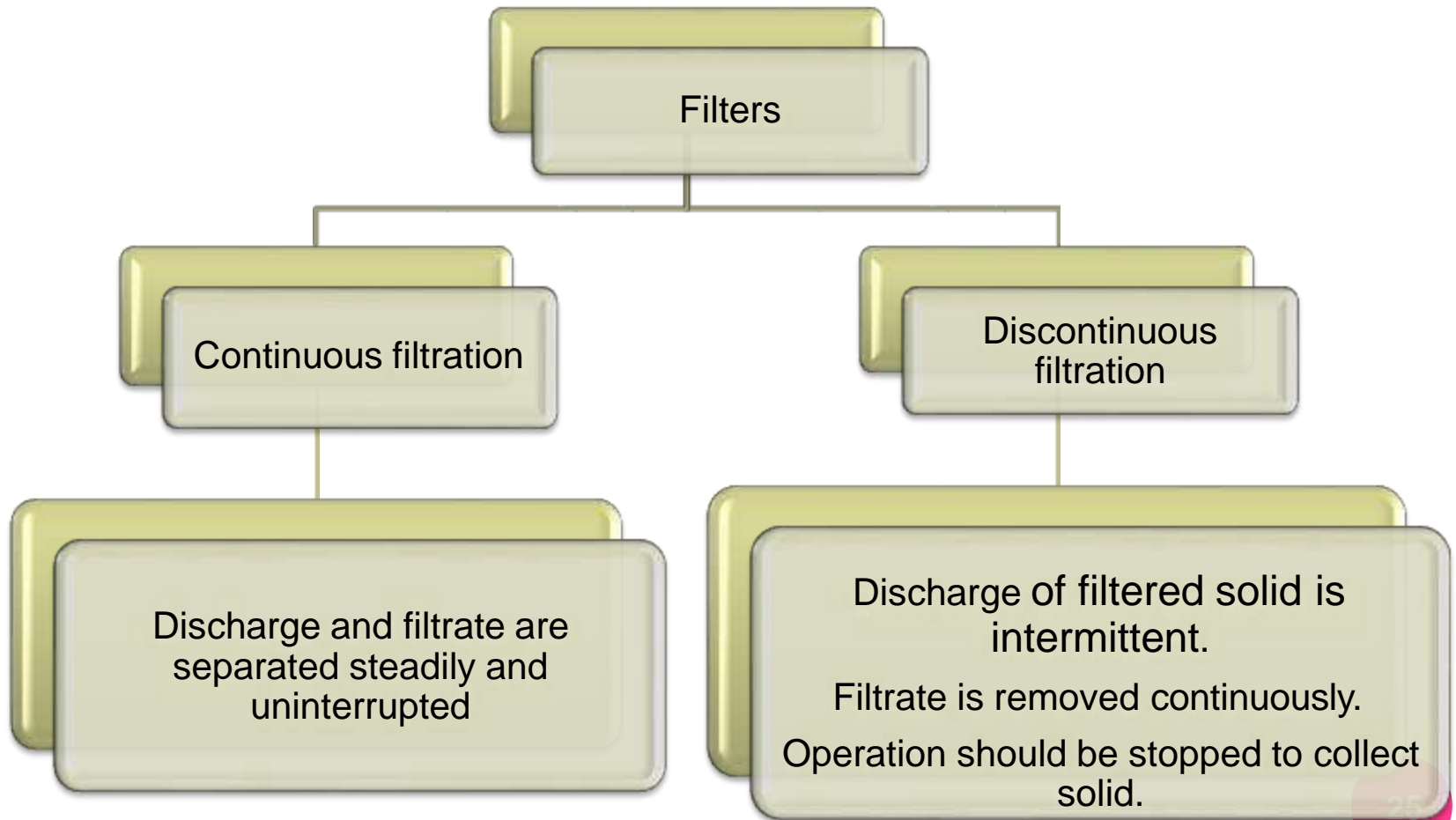

BASED ON NATURE OF FILTRATION

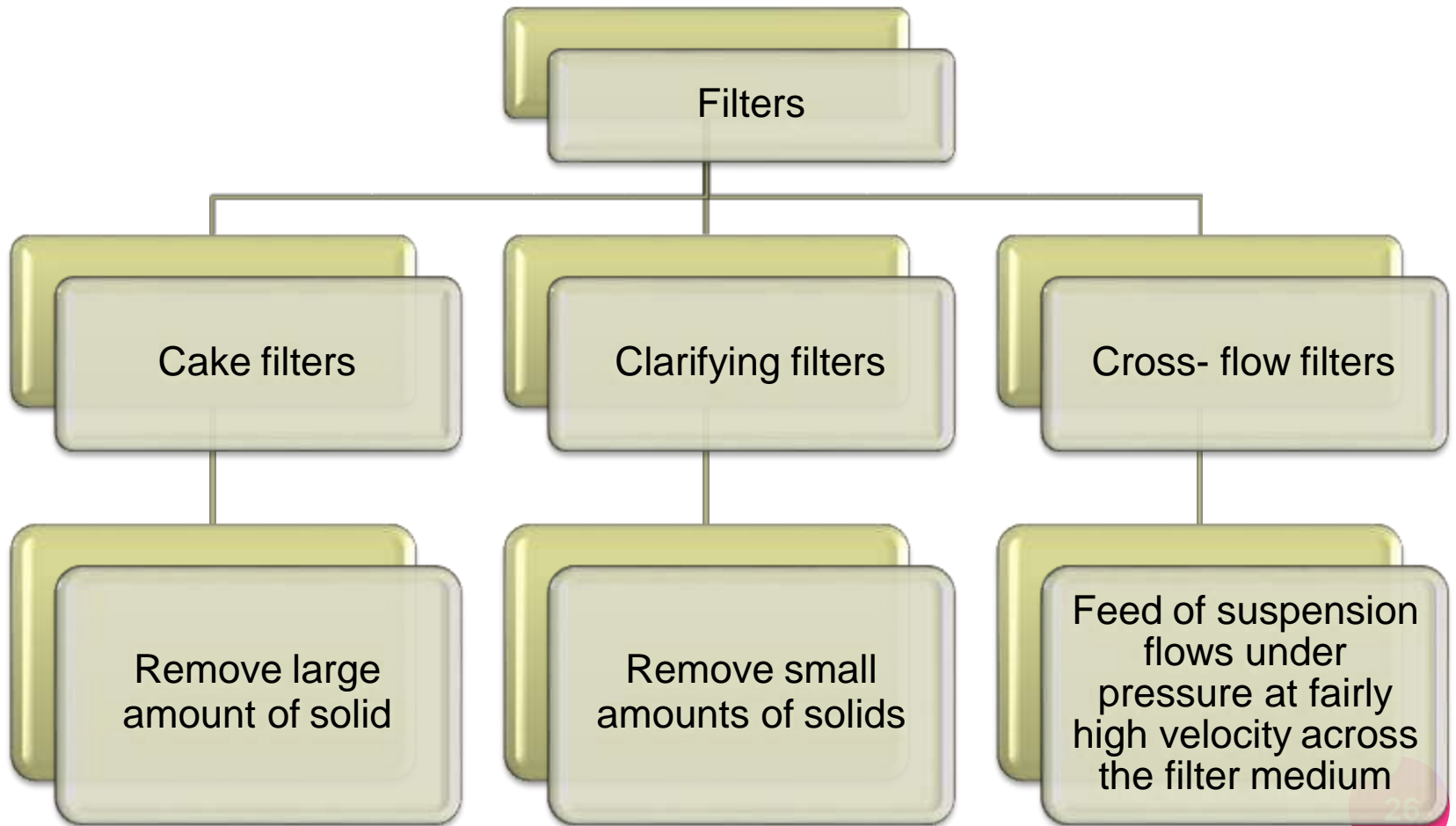

LABORATORY SCALE FILTRATION

- Filter paper and funnel
- Buchner funnel and filter paper
- Sintered glass filter
- Seitz filter
- Membrane filter

SELECTION OF FILTERS DEPENDS UPON

below listed factors

Material related

Properties of fluid- viscosity

Nature of solids- size, shape, distribution and packing characteristics of particles

Conc. Of solid in suspension

Quantity of material to be handle

Whether it is necessary to wash the solid

Whether any form of pretreatment will be helpful.

Equipment and process related

Flow rate

Should be absolute in sense, limit to size of particles passing through the filter should be known.

Should be sterilisable by heat, radiation or gas

Should be economical.

PLATE AND FRAME FILTER PRESS

- Principle:
 - Mechanism is surface filtration.
 - The slurry enters the frame by pressure and flows through filter medium.
 - The filtrate is collected on the plates and send to outlet.
 - A number of frames and plates are used so that surface area increases and consequently large volumes of slurry can be processed simultaneously with or without washing.

DIAGRAM

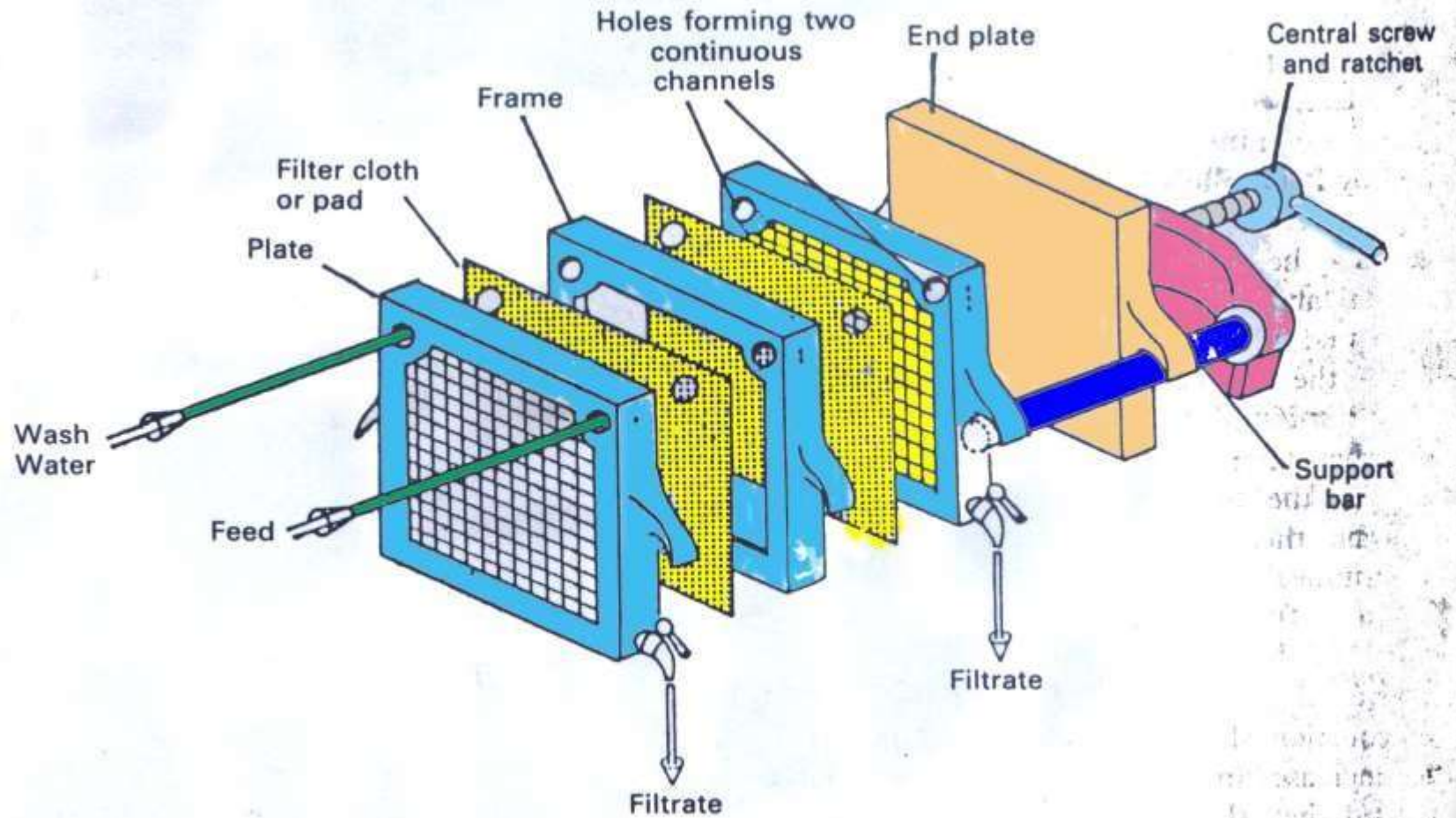
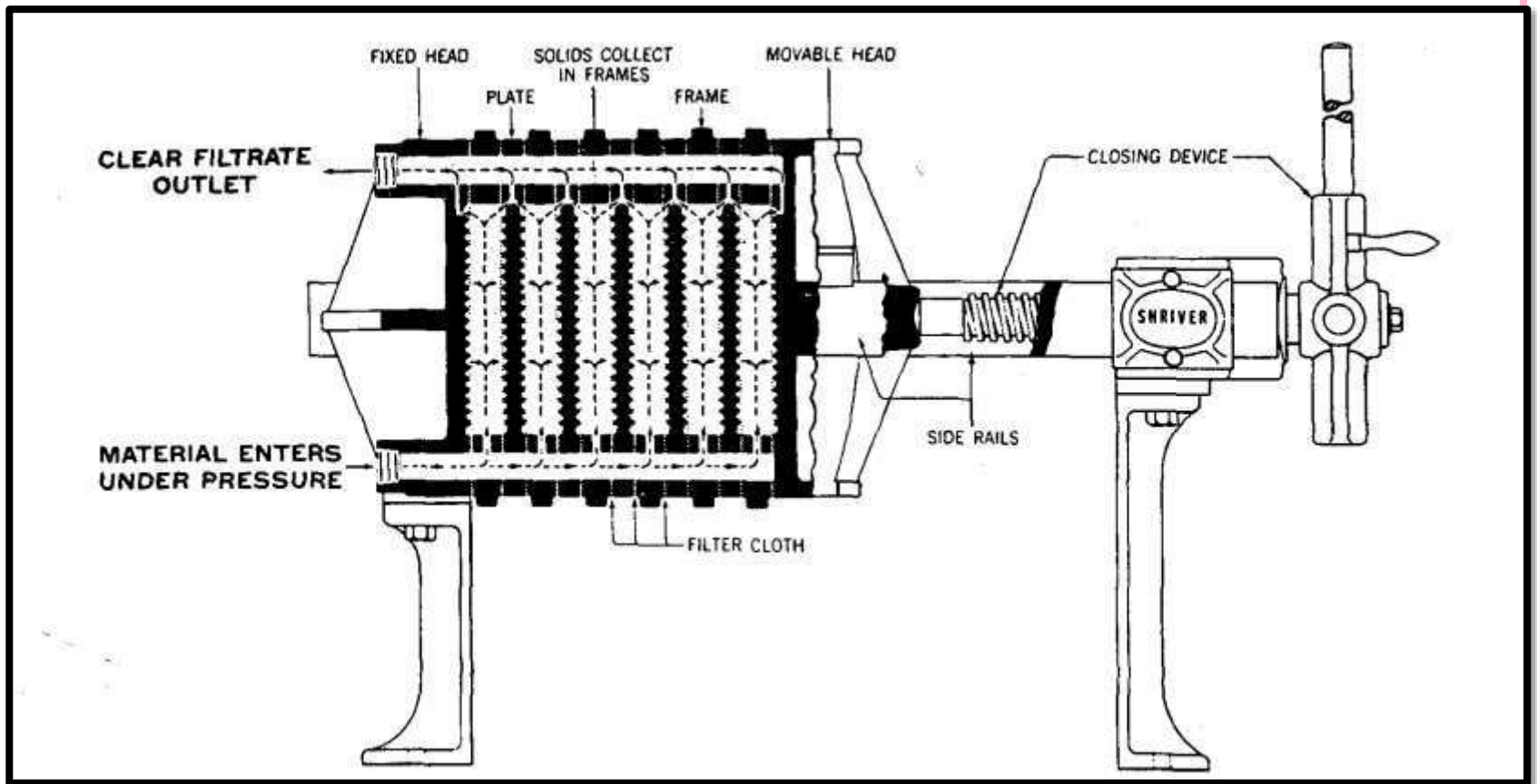

Fig. 31.5 Filter press. Assembly of plates and frames

ASSEMBLY OF PLATE AND FRAME FILTER



CONSTRUCTION

- The Filter press is made of two types of units, plate and frames.
- Usually made of aluminium alloy.
- Sometimes, these are also lacquered for protection against corrosive chemicals and made suitable for steam sterilization.
- **Frame**
 - It contains a open space inside wherein the slurry reservoir is maintained for filtration and an inlet to receive the slurry.
 - It is indicated by two dots in description.

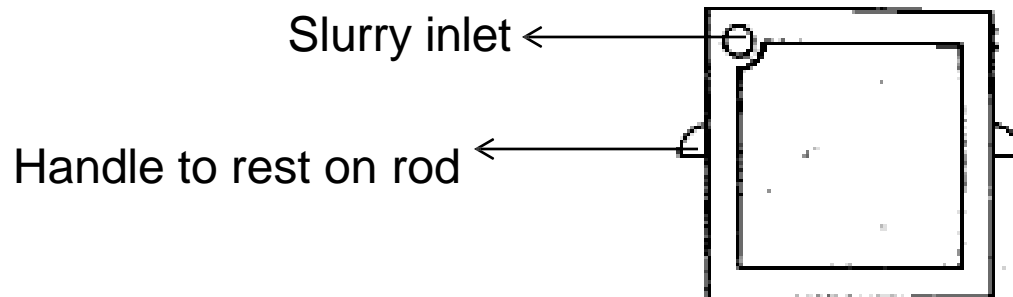

CONTINUE

....

- Frames of different thickness are available.
- It is selected based on the thickness of cake formed during filtration.
- Optimum thickness of frame should be chosen.
- **Plate**
 - The plate has a studded or grooved surface to support the filter cloth and an outlet.
 - It is indicated by one dot in description.

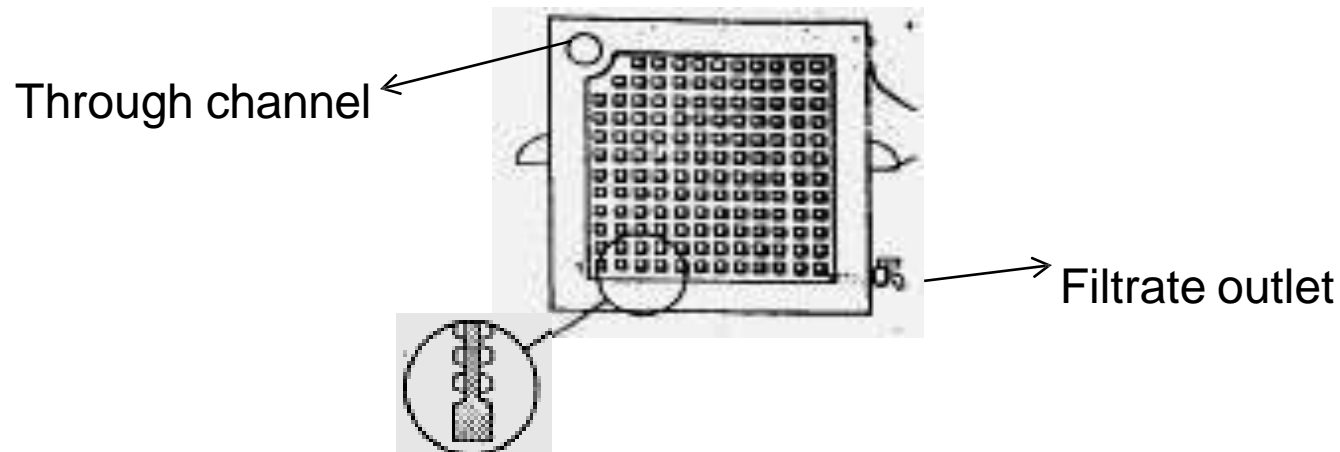

CONTINUE

....

- Plate supports the filter medium, receiving the filtrate and outlet.
- The filter medium usually cloth is interposed between plate and frame.
- Plate, filter medium, frame, filter medium and plate are arranged in sequence and clamed to a supporting structure.
- It is normally described by dots as 1.2.1.2.1 so on.
- A number of plates and frames are employed so that the filtration area is as large as necessary.
- Number of filtration units are operated in parallel.
- Channels for slurry inlet and filtrate outlet can be arranged by fitting eyes to the plates and frames, these join together to form a channel.
- In some types only one inlet channel is formed, while each plate is having individual outlets controlled by valves.

WORKING

- Working can be divided into two steps-
 1. Filtration operation
 2. Washing of cake (if desirable)
- Filtration operation

Frame- marked by 2 dots
Plate – marked by 1 dot

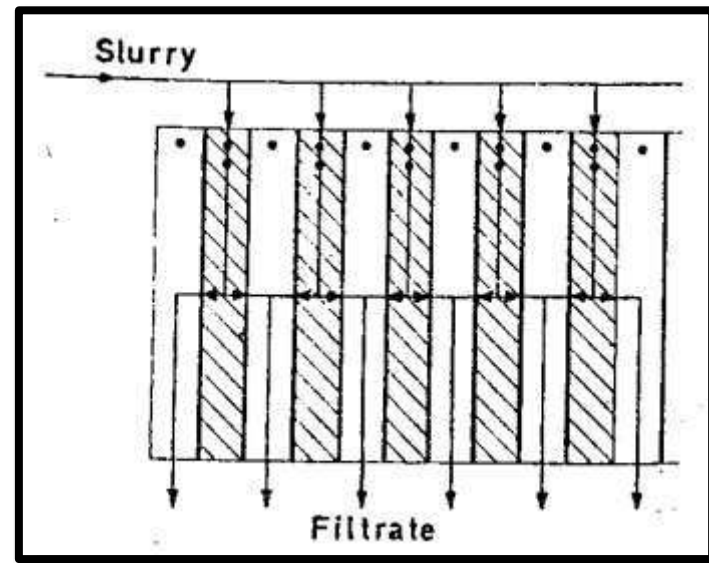
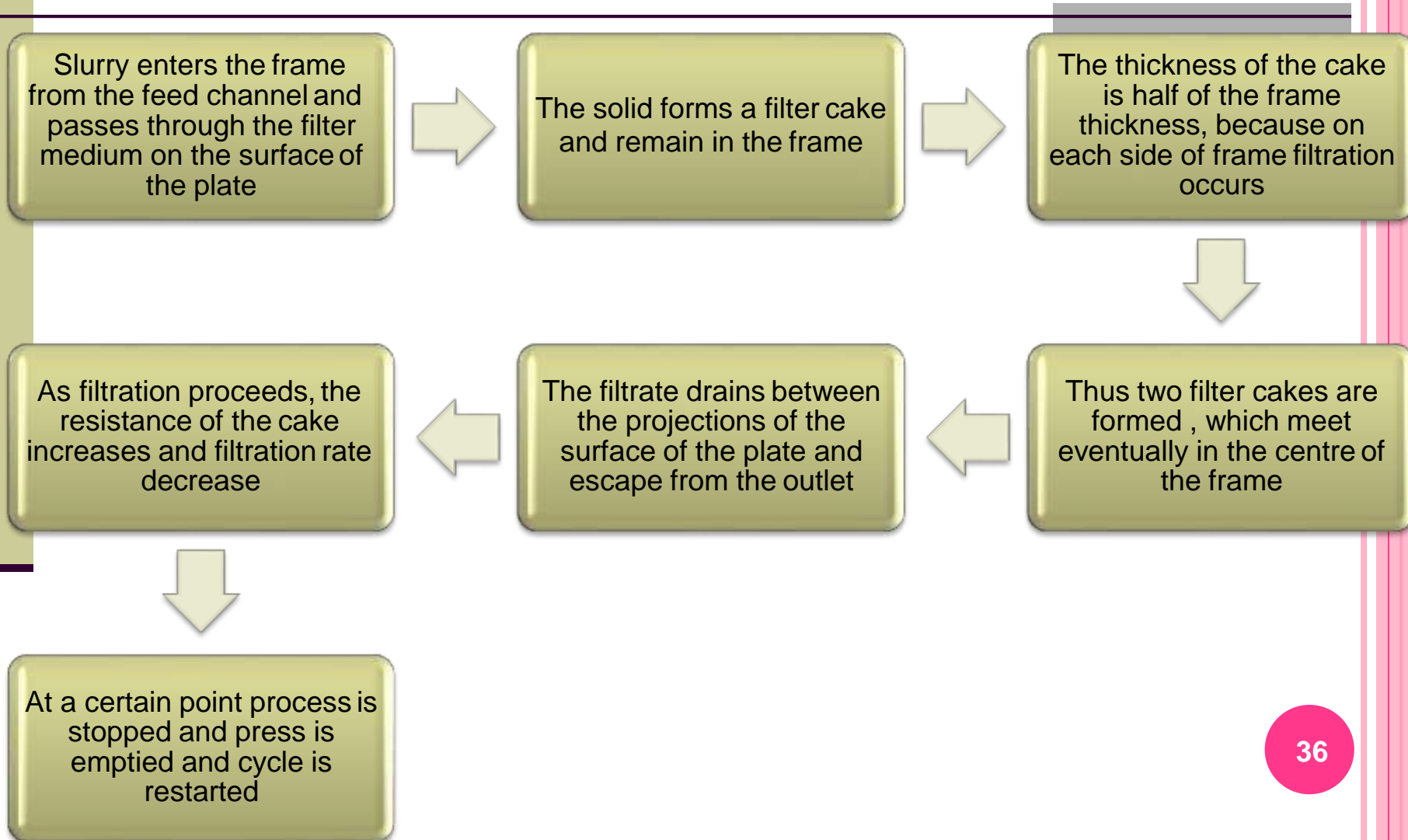

Plate and frame filter press, principle of filtration operation

CONTINUE.....



WASHING OPERATION

- When washing of cake is also required modified plate and frame filter is used.
- For this purpose an additional channel is included called as washing plate and are identified by 3 dots.
- In the half of the washing plate, there is a connection from wash water channel to the surface of plate.
- The sequence of arrangement of plates and frames can be represented by dots as 1.2.3.2.1.2.3.2.1 so on (between 1 and 1, 2.3.2 must be arranged).

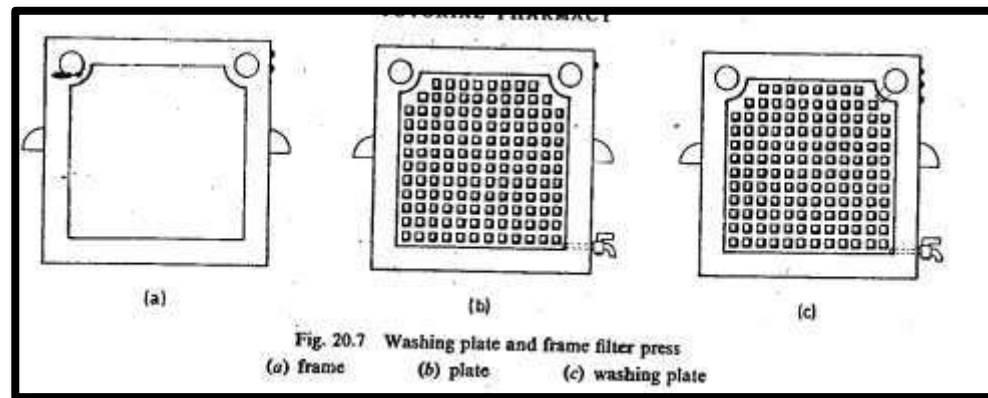

PROCEDURE FOR WASHING THE PRESS

Step 1

- Filtration proceeds in the ordinary way until the frames are filled with cake.

Step 2

- To wash the filter cake, the outlets of washing plates are closed.

Step 3

- Wash water is pumped in the washing channel.
- The water enters through the inlets on the surface of washing plate.

Step 4

- Water passes through the filter cloth and enters frame which contains the cake.
- Then water washes the cake, passes through the filter cloth and enters the plate down the surface.

Step 5

- Finally washed water escapes through the outlet of that plate.

DIAGRAMMATIC PROCEDURE

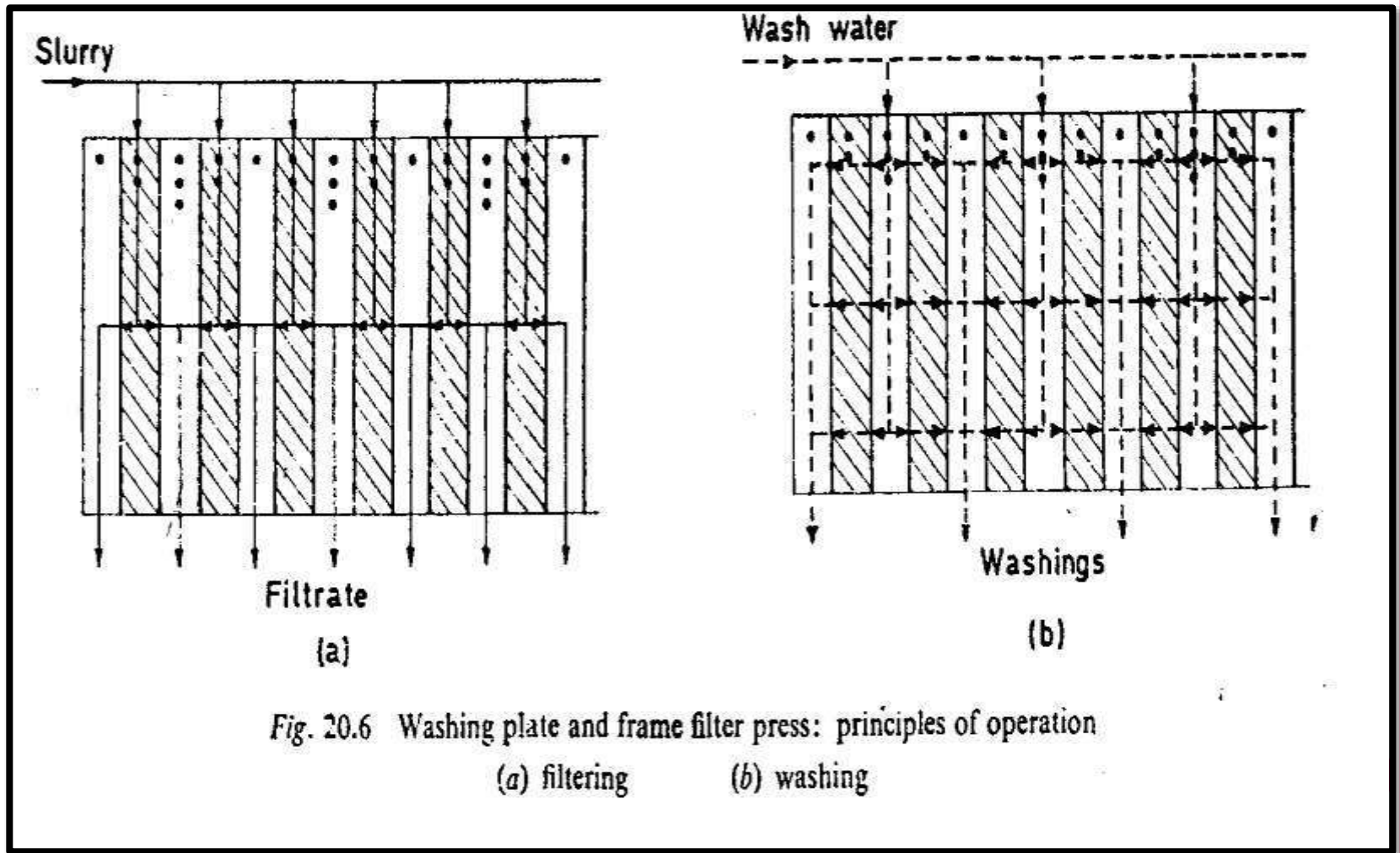

Fig. 20.6 Washing plate and frame filter press: principles of operation

(a) filtering

(b) washing

THINGS TO BE NOTED

- Water – wash is efficient only if the frames are full with filter cake.
- If the solid do not fill the frame completely, the wash water causes the cake to break (on the washing plate side of the frame), then washing will be less effective.
- Hence it is essential to allow the frames become completely filled with washing cake.
- This helps not only in emptying the frames but also helps in washing the cake correctly.



SPECIAL PROVISIONS AND USES

- Special provisions:
 - 1. Any possible contamination can be observed by passing the filtrate through a glass tube or sight glass from the outlet on each plate.
 - This permits the inspection of quality of filtrate. The filtrate goes
 - through the control valves to an outlet channel.
 - 2. The filtration process from each plate can be seen.
 - In the event of broken cloth, the faulty plate can be isolated and filtration can be continued with one plate less.
- Uses: heating/cooling coils in the press.



ADVANTAGES

- Construction of filter press is very simple and a variety of materials can be used.
 - I. Cast iron – for handling common substances.
 - II. Bronze - for smaller units.
 - III. Stainless steel – contamination can be avoided.
 - IV. Hard rubber and plastic- used where metals must be avoided.
 - V. Wood- for lightness though it must be kept wet.
- Provide large filtration area in relatively small floor space. The capacity being variable according to thickness of frames and number used.
- Sturdy construction permits the use of considerable pressure difference. (2000 Kilopascals normally used)
- Efficient washing of cake is possible.
- Operation and maintenance is easy.
- It produce dry cake in form of slab.



DISADVANTAGES

- It is a batch filter, so it is a time consuming.
- The filter press is an expensive filter, the emptying time, the labour involved, and the wear and tear on the cloths resulting in high costs.
- Operation is critical, as the frames should be full, otherwise washing is inefficient and the cake is difficult to remove.
- The filter press is used for slurries containing less about 5 % solids
- In view of the high labour costs , it is most suitable for expensive materials e.g. the removal of precipitated proteins from insulin liquors.

CHAMBER PRESS

Principle

- Mechanism is surface filtration.
- The slurry enters the frame by pressure and flows through the filter cloth.
- The filtrate is collected on the plates and send to the outlet.
- A number of head plates are used, so that the surface area can be increases and consequently large volumes of slurry can be processed simultaneously.

DIAGRAM

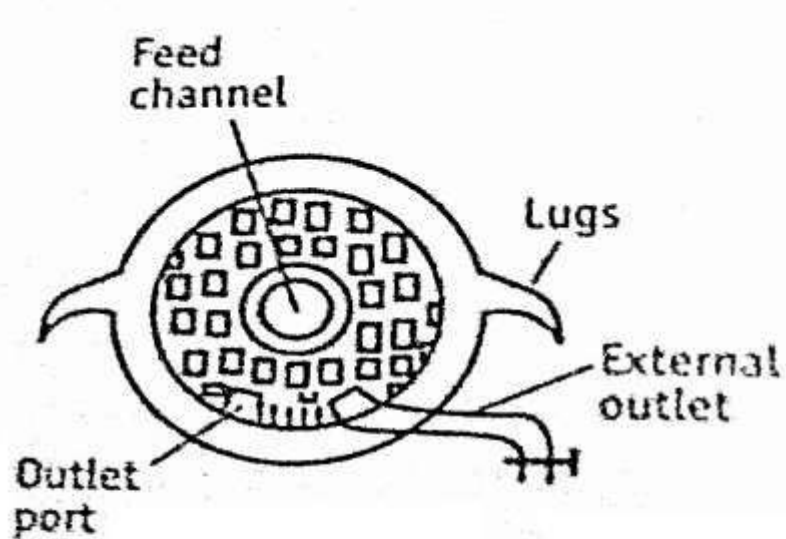

(a) Cast iron plate of chamber press.

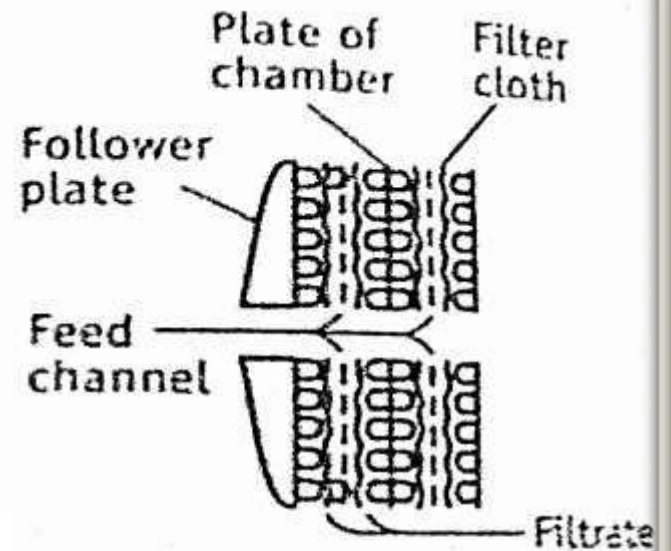

(b) Principle of filtration

Chamber filter.

CONSTRUCTION

- It consist of heavy fixed head plate made of cast iron and mounted on
 - suitable frame.
- Extending from the head plate, two horizontal bars support on both ends.
- The bar supports the plate by lugs.
- At the center of the each plate, a hole is provided for introducing the
 - feed.
- The holes of the all plate are connected on the head of the press.
- Over each press plate, a sheet of filter cloth with a hole cut in the centre and is placed.
- The filter cloth is fastened by means of rings called grommets and
 - either screwed together or locked.
- These draw down the cloth, so that it is shaped round the plate.
- **The cloth serves as a gasket between the adjacent plates.**
- All such plates are arranged and a heavy follower plate is placed behind and tighten.



WORKING

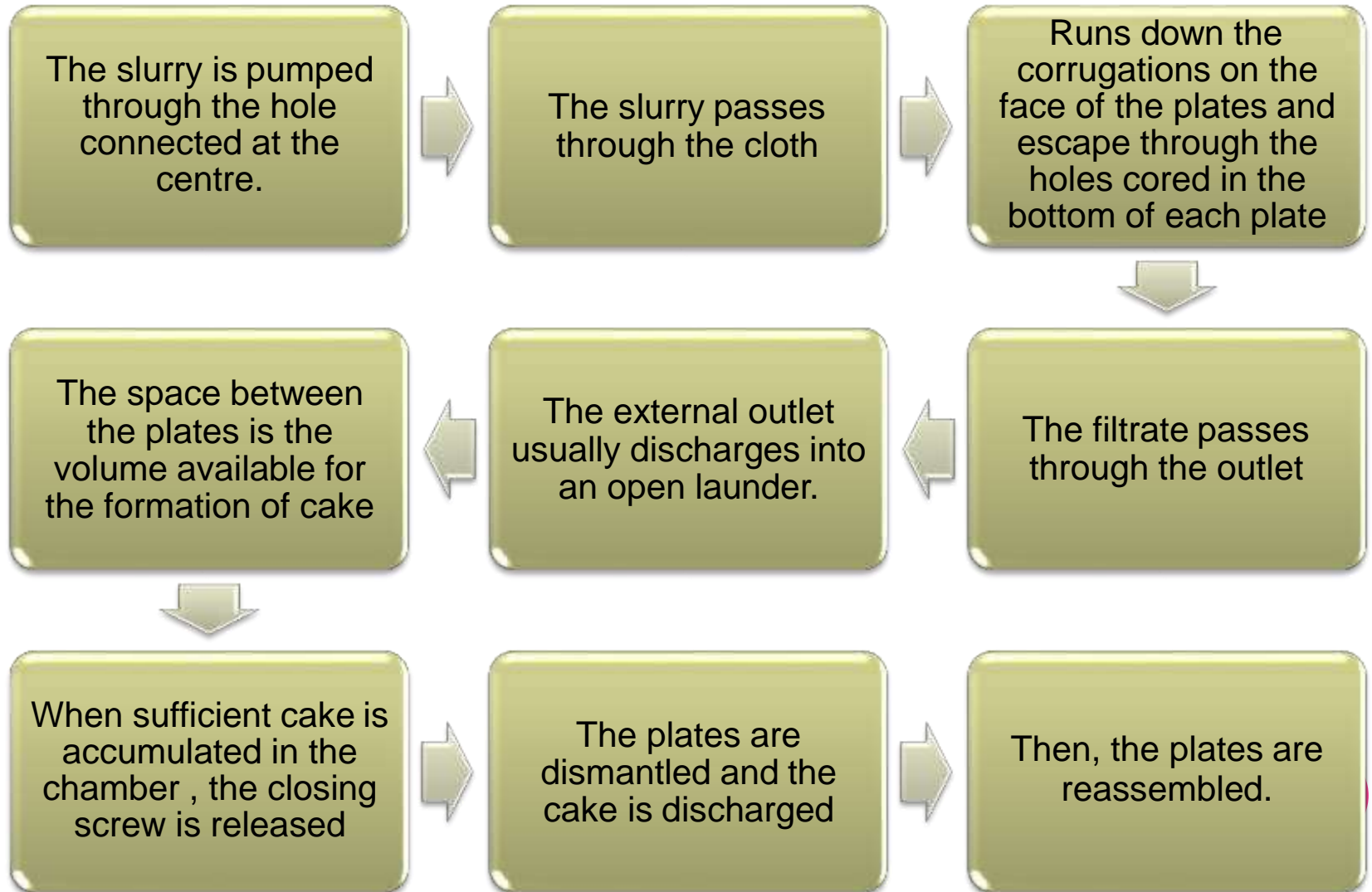

USES, ADVANTAGES AND DISADVANTAGES

Uses:

- used for clarification of syrups and filtrating of injection solutions.

Advantages:

- Provide large filtering area in relatively small floor space.
- A number of head plates can be increased or decreased as per need.
- Operation and maintenance are straight forward (no moving part).
- Filter cloths are easily renewable.

Disadvantages:

- Not adaptable for washing of cake.
- The wear of cloth is severe.
- The filtrate is usually not clear.

FILTER LEAF

Principle:

- It is an apparatus consisting of a longitudinal drainage screen covered with a filter cloth.
- The mechanism is surface filtration and acts as sieve or strainer.
- Vacuum or pressure can be applied to increase the rate of filtration.

Construction:

- The leaf filter is consisting of a frame enclosing a drainage screen or grooved plate.
- The frame may be any shape circular, square or rectangular.
- The whole unite being covered with filter cloth.
- The outlet for the filtrate connects to the inside of the frame through suction.

DIAGRAM

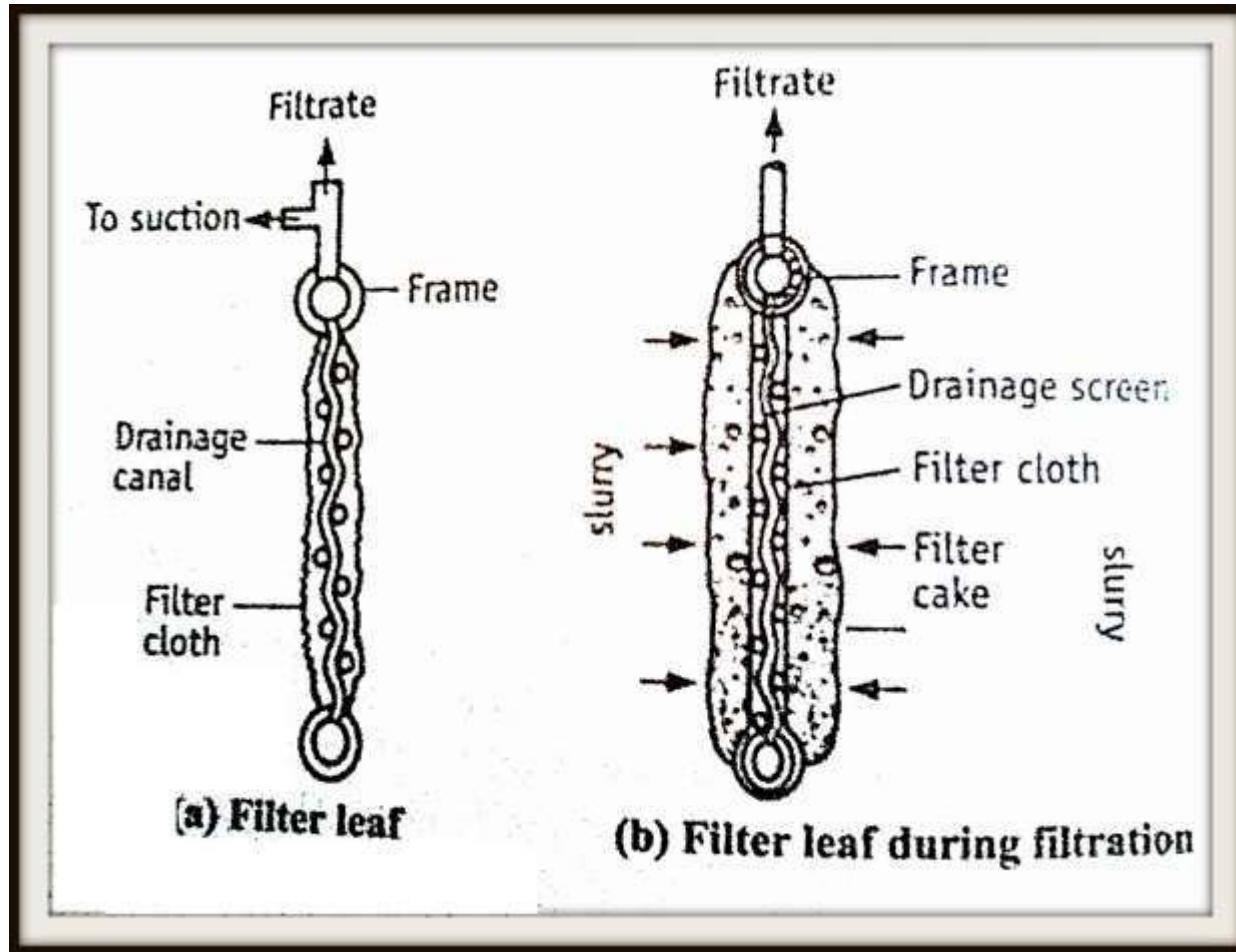

WORKING AND USES

Working:

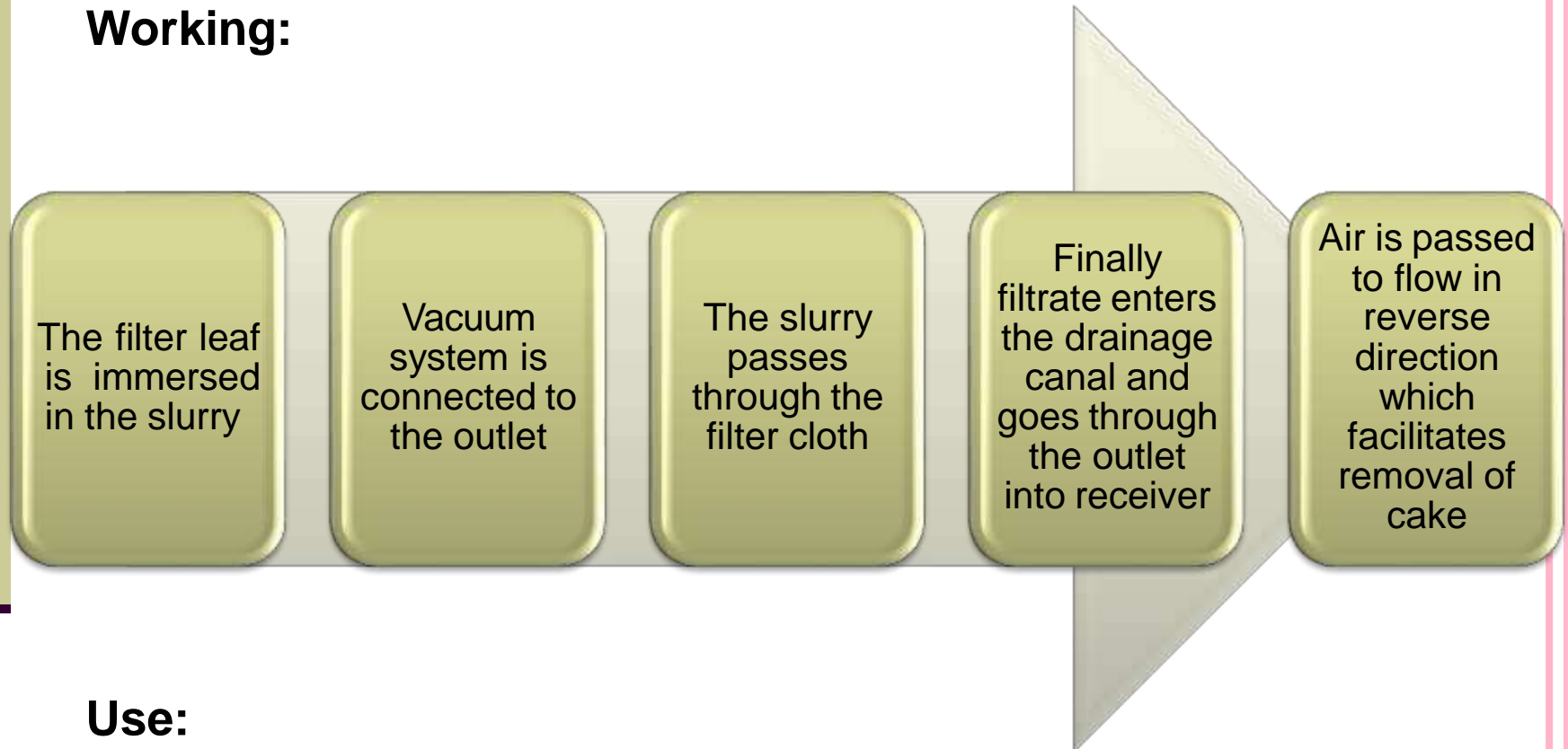

Use:

- Use for the filtration of slurry which do not contain high solid content, about 5%, i.e. dilute suspensions.

ADVANTAGES

- Simplest form of filter used for batch process.
- A number of units can be connected in parallel to increase the surface area of filtration.
- Pressure difference can be obtained either with vacuum or using pressure up to the order of 800 kilopascals.
- Labour costs for operating the filter leaf are fairly moderate.
- The efficiency of washing is high.
- The slurry can be filtered from any vessel.
- The cake can be washed simply by immersing the filter in a vessel of Water.

SWEETLAND FILTER (VARIANT OF FILTER LEAF)

- An alternative method is to enclose the filter leaf in a special vessel into which the slurry is pumped under pressure.
- A number of leaves are connected to a common outlet, to provide a large area for filtration.

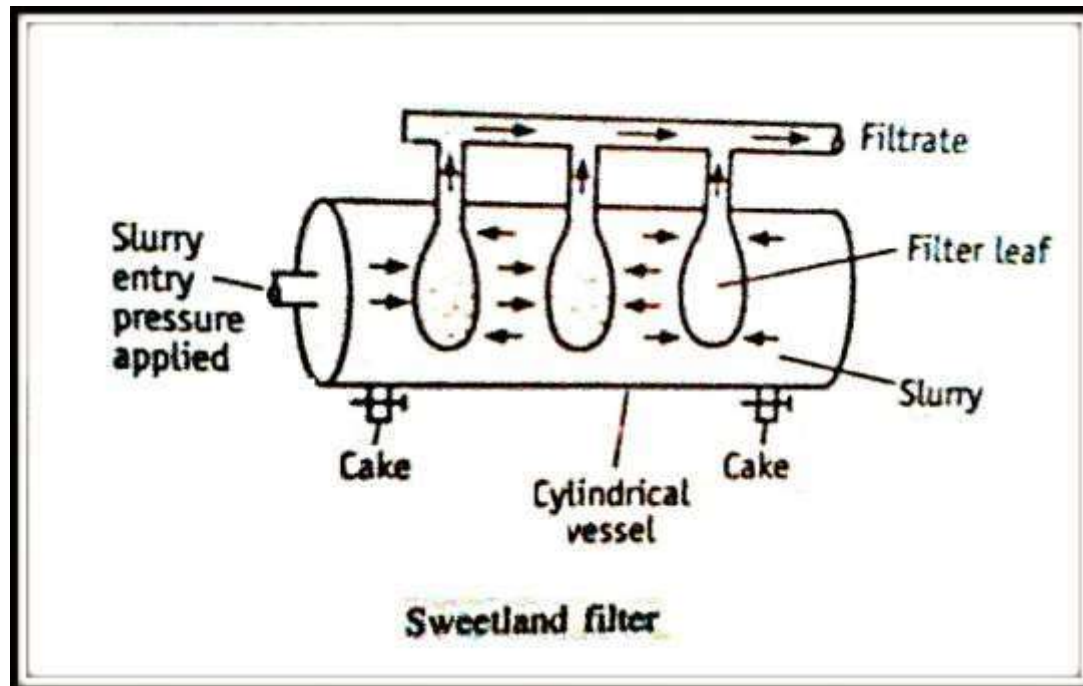

METAFILTER

○ Principle:

- Mechanism is surface filtration.
- In this, metal rings contain semicircular projections, which are arranged as a nest to form channels on the edges.
- This channel offers resistance (strainer) to the flow of solids (coarse particles).
- The clear liquid is collected into receiver from the top.

CONSTRUCTION

- Metafilter consists of a series of metal rings.
- These are threaded so that a channel is formed on the edges.
- It contains a grooved drainage column on which a series of metal rings are packed.
- These rings are usually made up of stainless steel and have dimensions of about 15.0 mm internal diameter and 22.0 mm external diameter.
- Each metal ring has a number of semicircular projections (0.8 mm in thickness) on one side of surface.
- The projections are arranged as a nest to form channels on the edges.
- These rings are tightened on the drainage column with a nut.
- Metafilters are also known as edge filters.

DIAGRAM

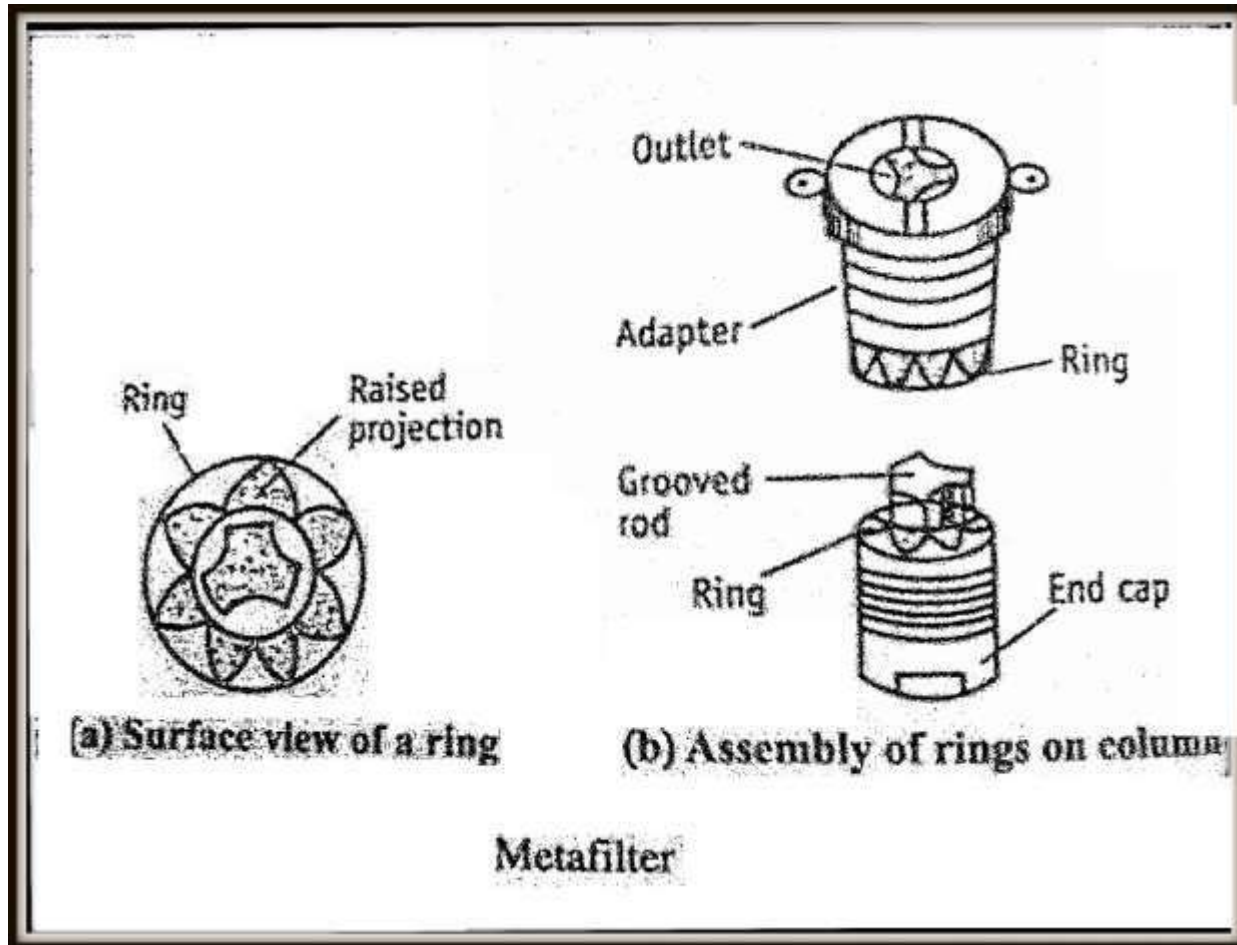

WORKING

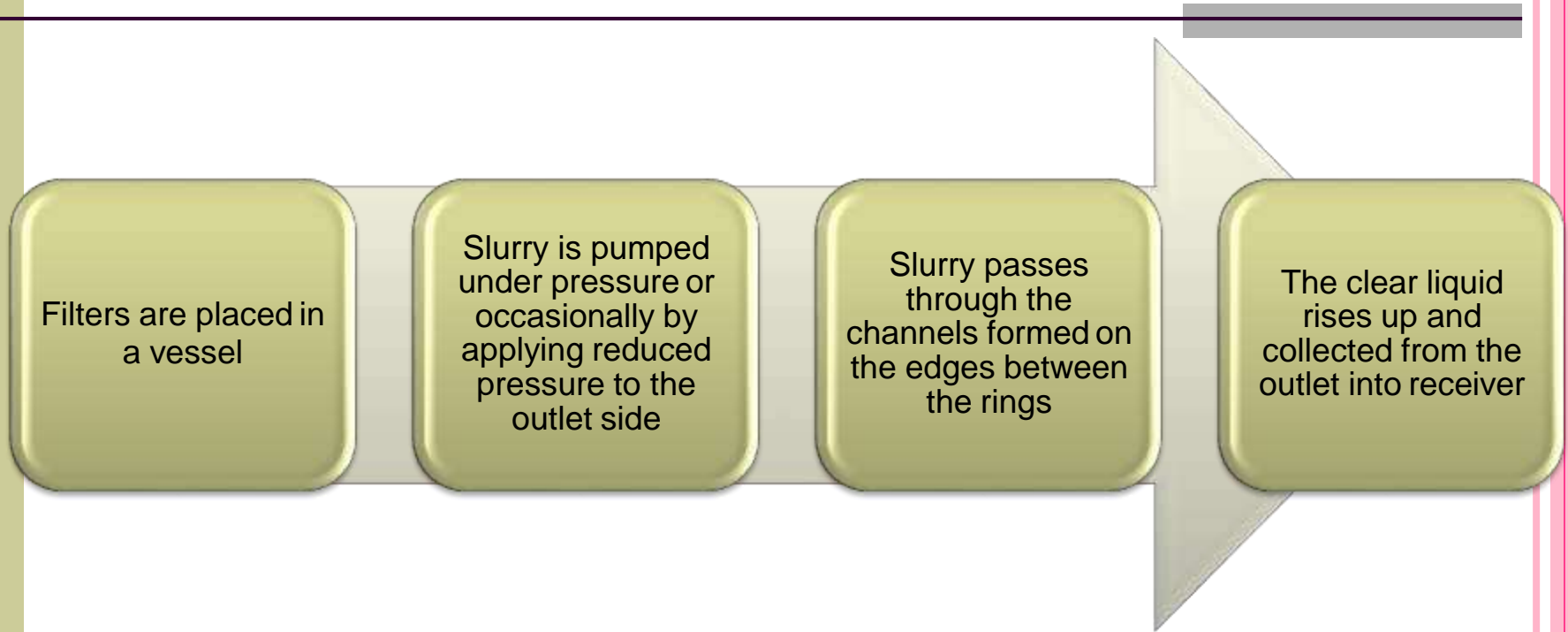

- For separation of fine particles, a bed of suitable materials such kieselguhr is first built up.
- The pack of rings serves essentially as a base on which the true filter medium is supported.

USES

- Metafilters can be used for-
 - Clarification of syrups
 - Filtration of injection solutions
 - Clarification of insulin liquors
 - Filtration of viscous liquids can be achieved by applying pressure.

ADVANTAGES

- Can be used under high pressures, without any danger of bursting the filter medium.
- Running cost are low, as separate filter medium is not used.
- Can be constructed from a material that can provide excellent resistance to corrosion and avoid contamination of sensitive products.
- It is extremely versatile filter because fine as well as large both type of particles can be separated.
- Removal of cake can be carried out by simply back- flushing with water.
- Change over from one batch to another or one product to another is easy.
- Sterile products can be handled.

CARTRIDGE FILTER

Principle:

- It is a thin porous membrane in which pre filter and membrane filter are combined in a single unit.
- The filtration action is mainly sieve like and particles are retained on the surface.

Construction:

- It has cylindrical configuration made with disposable or changeable filter media.
- Made up of either plastic or metal.
- Consist of two membrane filters (sieve like) made of polypropylene: pre filter and actual filter for filtration.
- A protective layer surrounds them.
- The cartridge are housed in a holder and a number of cartridges can be placed in a same housing.
- The housing is closed with the lid.
- Housing has provisions for slurry inlet and outlets.



DIAGRAM

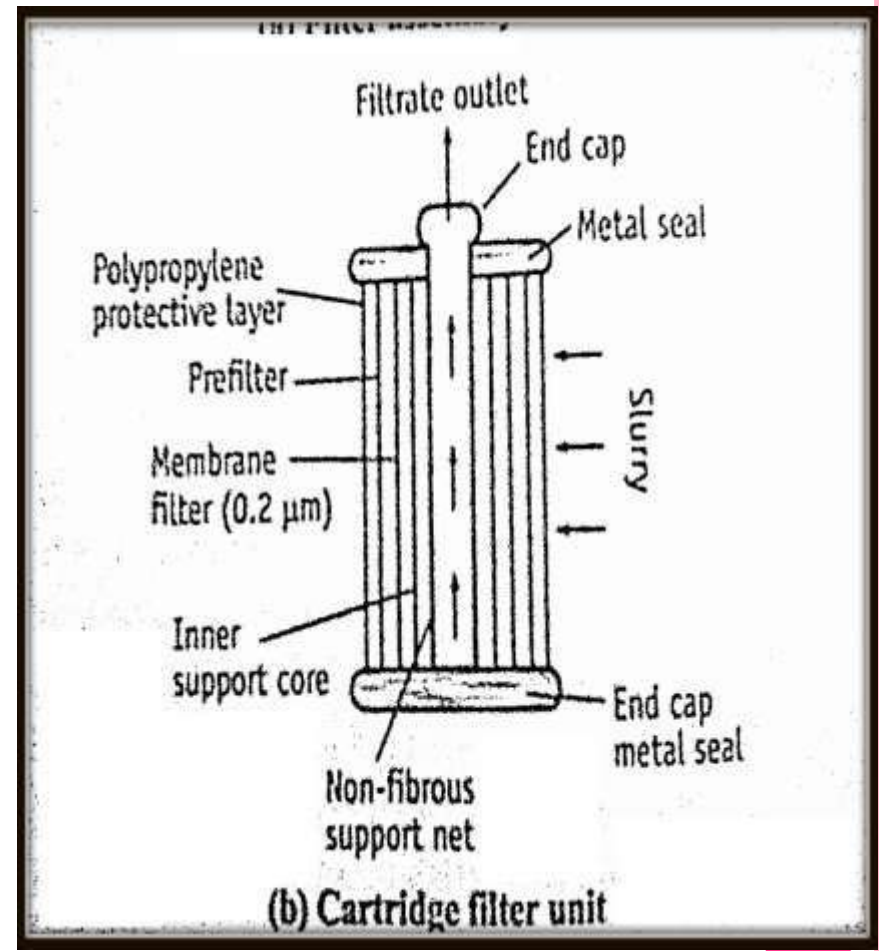
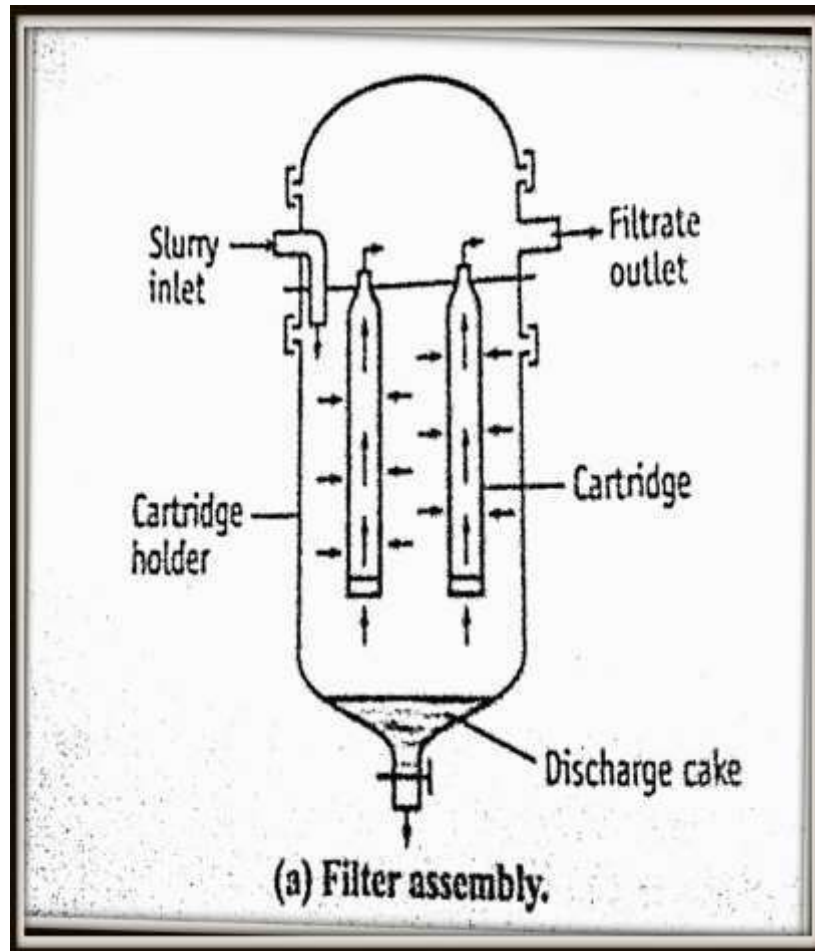

WORKING AND USES

Working:

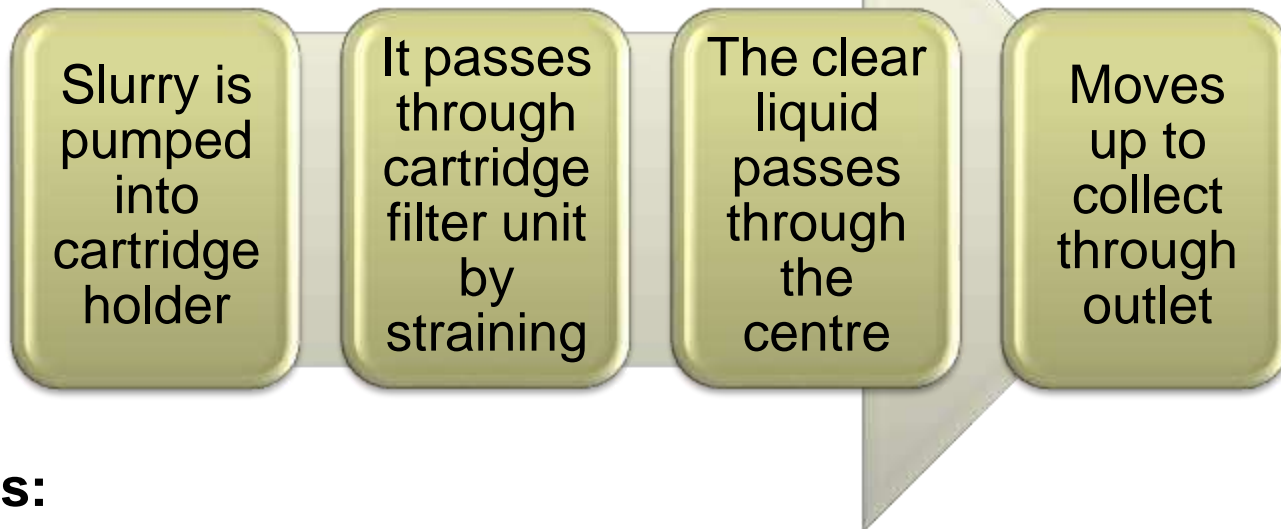

Uses:

- Particularly useful for preparation of particulate free solutions for parenterals and ophthalmic uses.
- This filter holder will process 1000 – 15000 litres of sterile solution per hour.

ADVANTAGES AND DISADVANTAGES

Advantages:

- Autoclaving can be done for sterile operations due to stainless steel construction.
- Cartridge with self cleaning devices are advantageous.
- Rapid disassembling as well as reusing of filter medium is possible.
- Cartridge are not brittle, when they are dry.
- Used as in-line continuous filtration, which reduces handling of solutions. It minimize chances of contaminations.

Disadvantages:

- A number of manufactures provide the components, which are generally not interchangeable between suppliers.
- Cost of disposable elements offsets the labour saving in terms of assembly and cleaning of cartridge clarifiers.

ROTARY DRUM FILTER

○ Principle:

- Slurry filtered through sieve like mechanism on the rotation drum surface, under the condition of vacuum.
- In addition compression, drying (using hot air), and removing the filter cake (using knife) are possible.

○ Construction:

- It consist of a metal cylinder mounted horizontally.
- The drum may be up to 3 meters in diameter and 3.5 meters in length and gives surface area of 20 meter square.

DIAGRAM

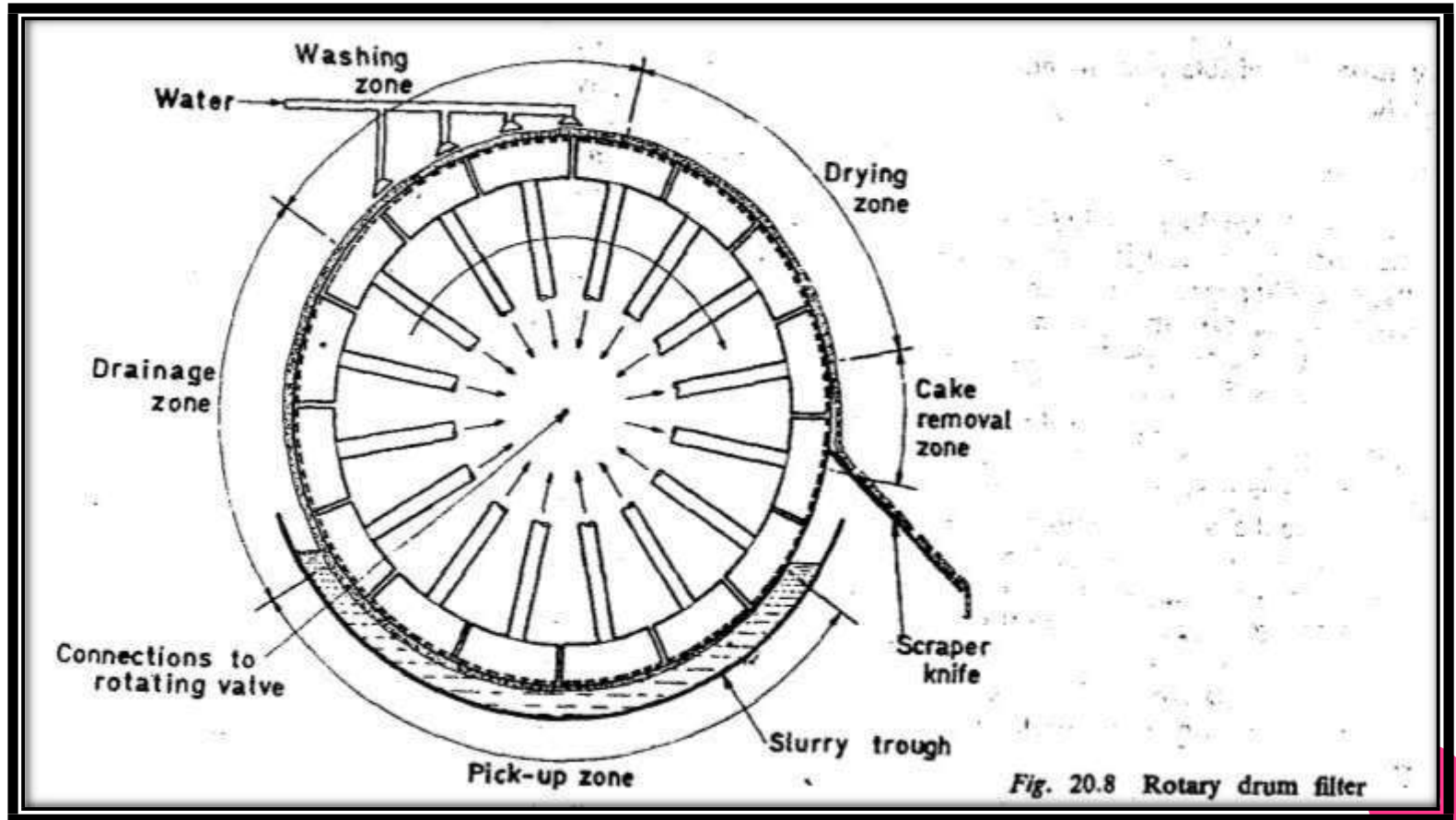

WORKING

- The drum is dipped into the slurry and vacuum applied to the outlet, which is connected to the filtrate receiver.
- When the cake has formed, the cake drained or partially dried by vacuum.
- The drum is sprayed with water to wash the cake.
- Retaining the vacuum connection drains the cake and produces partial dryness then, removed by a doctor knife.
- When the solids of the slurry are too much that the filter cloth becomes blocked with the particles, a pre-coat filter may be used.
- A pre-coat of filter aid is deposited on the drum prior to the filtration process.

USES

- The rotary filter for continuous operation on large quantities of
 - slurry.
- Suitable for slurry contains considerable amounts of solids in the range 15-30%.

- Examples of pharmaceutical application include
 - the collection of calcium carbonate, magnesium carbonate, and starch.
 - The separation of the mycelium from the fermentation liquor in
 - the manufacture of antibiotics.

ADVANTAGES

- The rotary filter is automatic and is continuous in operation, so that the labour costs are very low.
- The filter has a large capacity , so it is suitable for the filtration of highly concentrated solutions.
- Variation of the speed of rotation enables the cake thickness to be controlled.
- Pre-coat of filter aid could used to accelerate the filtration rate.
- Filter has large surface area.

DISADVANTAGES

- The rotary filter is a complex piece of equipment , with many
 - moving parts and is very expensive,.
- In addition to the filter itself, some accessories are connected
 - ,e.g., a vacuum pump, vacuum receivers , slurry pumps and agitators are required .
- The cake tends to crack due to the air drawn through by the
 - vacuum system, so that washing and drying are not efficient.
- Being a vacuum filter, the pressure difference is

PRESSURE AND SAND FILTER

Principle:

- Depth filtration
- Mechanism is impingement and entanglement of solids on account of low pressure differential.
- The slurry enters the sand bed and the clear liquid is collected from the bottom outlet.

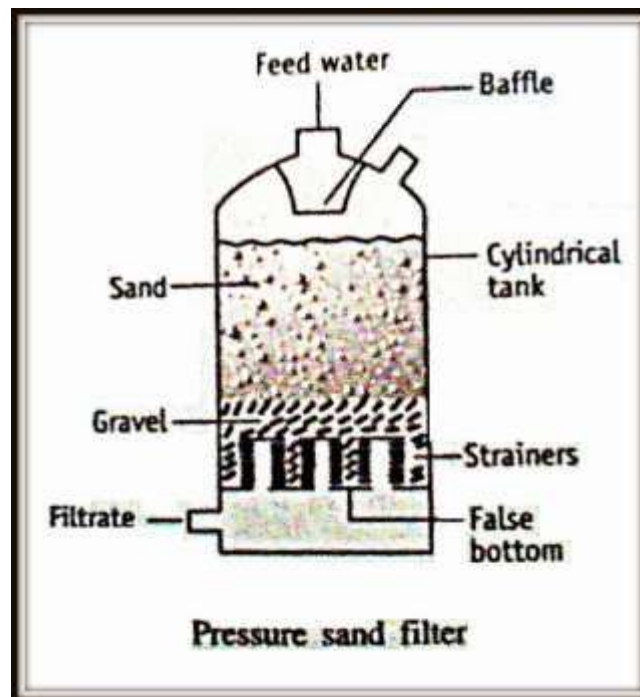

CONSTRUCTION

- It is a closed system and consists of cylindrical tank with a bottom containing a number of brass strainers.
- These are mounted on false bottom or connected to a modified embedded in concrete.
- The strainers have narrow slots sawed in them.
- Above this 6-12 m depth sand layer is placed, which acts as a filter medium.
- Baffles are arranged at the point of feed inlet, in order to prevent the disturbance of sand by direct stream.
- Provisions is made at the bottom for collecting the filtrate.

WORKING

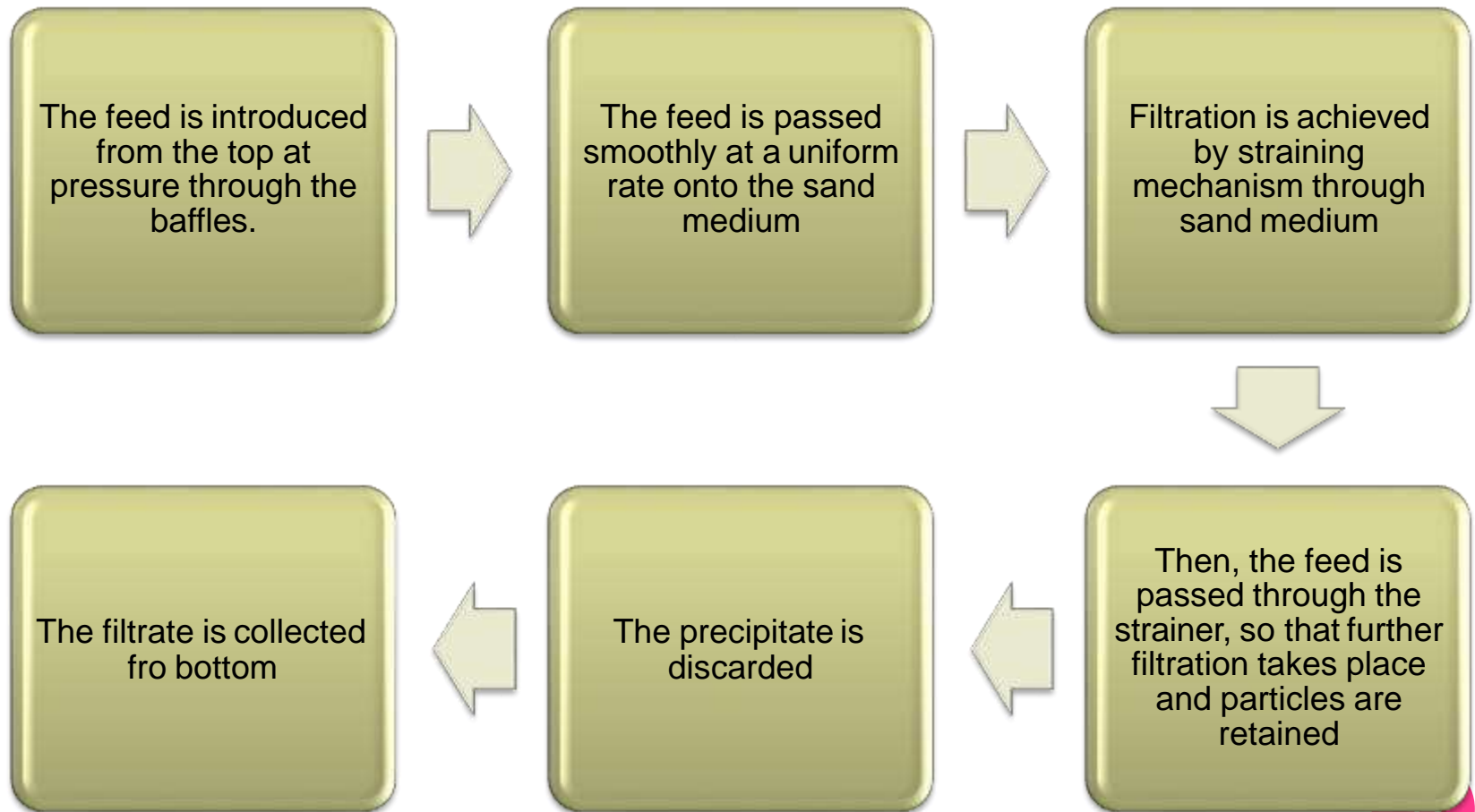

CONTINUE.....

- When the precipitate clogs the sand (indicated by reduced filtration rate), back washing permits the regeneration of the filter bed.
- During this operation, water moves up through the sand bed and moves out from the inlet.

Uses:

- Used for filtration of boiler feed or water for similar purposes.
- Mainly used when solids are little and large volume of feed is to be handled.
- They are applicable only to the separation of precipitates that can be removed from the sand.

DISADVANTAGES

- Feed containing precipitates that are gelatinous or form a coat on sand can't be filtered through the sand, because back washing does not permit regeneration.
- Feed containing finely divided solids can't be separate by this.
- Can't remove bacteria. In such cases, coagulants such as ferrous sulphate, are added to feed before filtration.

STREAMLINE FILTER

Principle:

- It consists of column of filter elements held tightly together, so that the slurry enters from the side of the column and passes through vary narrow channels between the elements.
- The filters employ paper discs.
- The filter act as a strainer to retain solids.

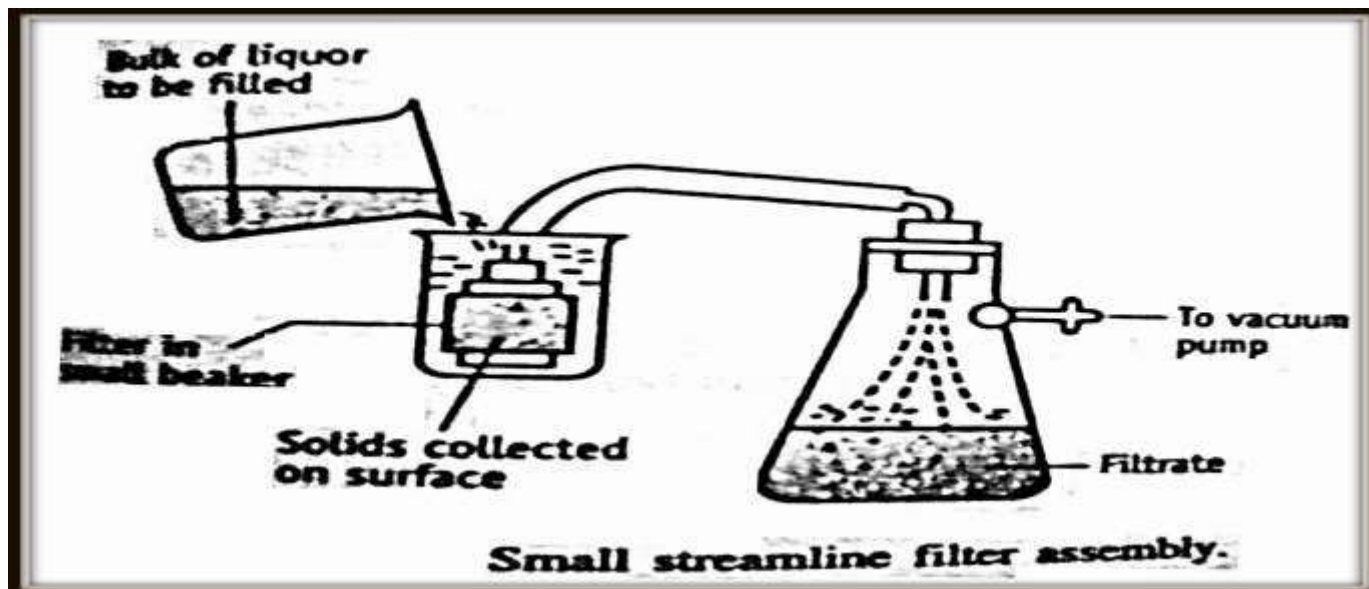

ASSEMBLY

- It consists of specially treated filter paper discs arranged in the form of a compressed pack on an upright rod or spigot.
- In assembling the filter, the two parts of the filter can be unscrewed.
- The required quantity of rings are placed on the spigot portion and two parts are then screwed together to give a compact stack of filter elements.
- The extent of compression on the disc may be varied depending on the size of particles to be removed.
- For small scale filtration, ebonite material made spigots are used.
- The spigot is hollow and grooves run down the length.
- From hollow centre of the spigot, vacuum is applied.

WORKING

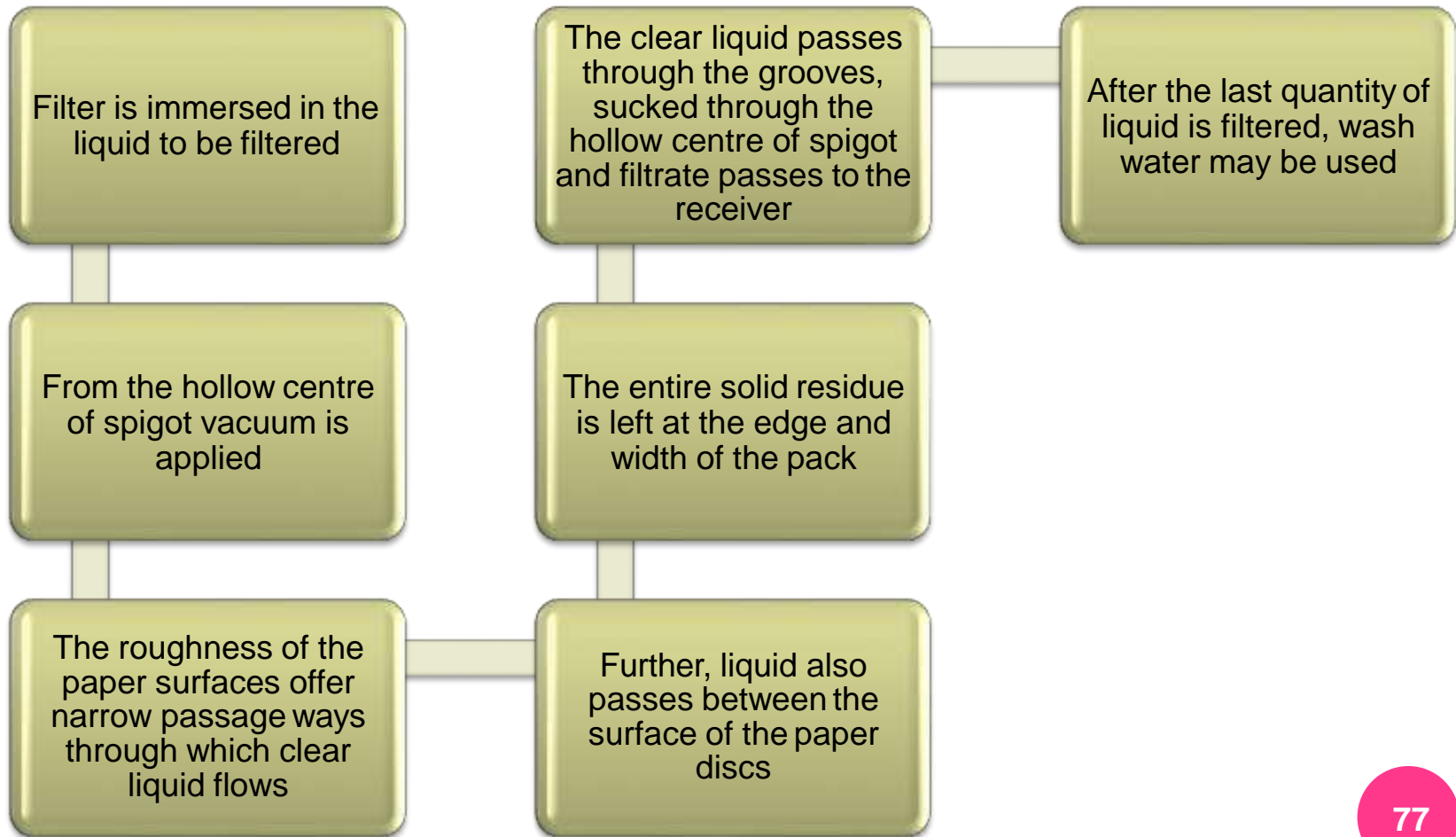

CONTINUE

....

- Cleaning of streamline filter is attempted by connecting the spigot to the water tap.
- The water is passed in opposite direction.
- The residue is washed away from the edges of the stack.
- If solid residue is required, air may be blown, so that solid is peeled of, which may be collected.

USES AND ADVANTAGES

Uses:

- It removes suspended matter, trace of fines and even submicron size colloidal matter from large volumes of the slurry.
- The two parts of spigots are screwed tightly and fine precipitates can be separated for achieving high grade polishing.
- Oily, aqueous and alcoholic solutions which do not soften the fibre of the pack can also be filtered.
- Heat resistant porcelain filters are used for strongly acidic or hot strong alkaline solutions.

Advantages:

- Instead of vacuum, pressure may be applied.
- In this case, the container (in which assembly is immersed) must be sealed and should be able to withstand applied pressure.



Thank you!