

ELECTROPHORESIS

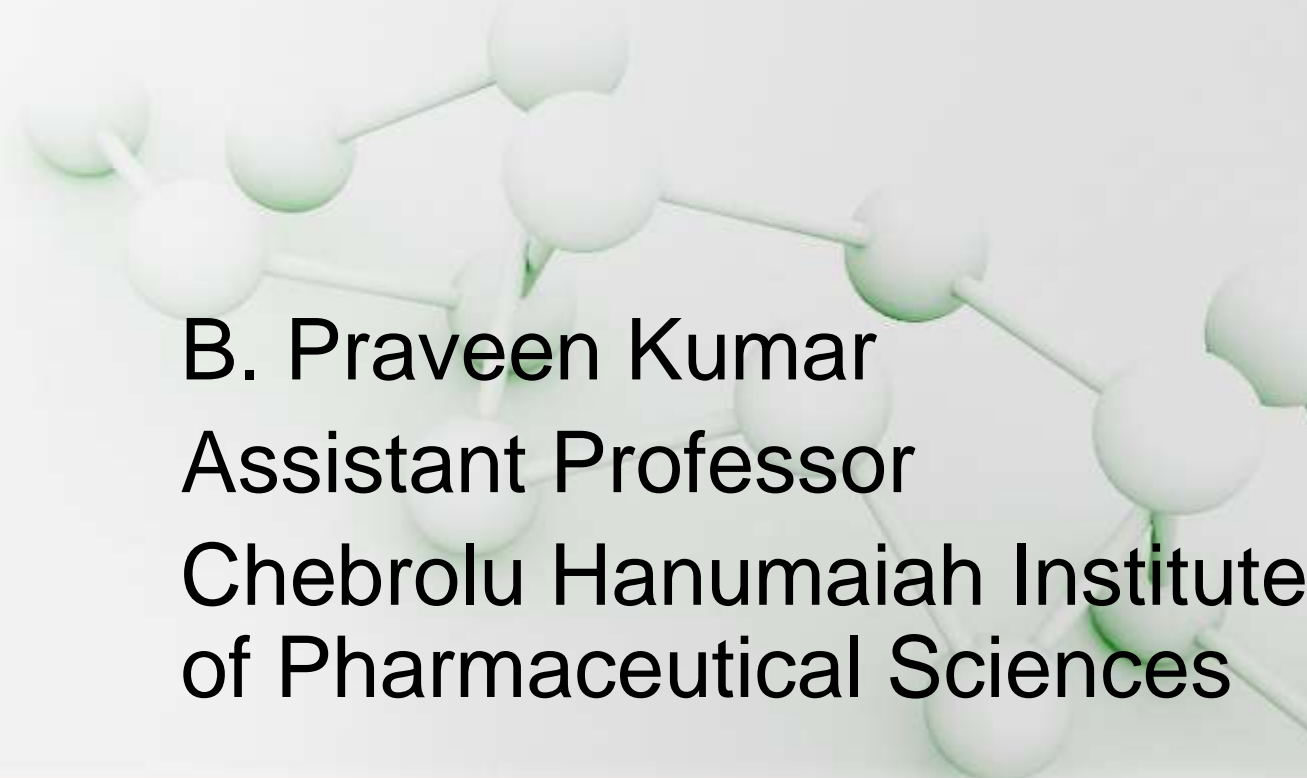

B. Praveen Kumar
Assistant Professor
Chebrolu Hanumaiah Institute
of Pharmaceutical Sciences

Introduction:

- Electrophoresis is comparatively a newer technique which can be applied to the migration of individual ions as well as to colloidal aggregates. This technique utilizes electrical properties of compounds.
- This separation technique was first developed by Swedish chemist Arne Tiselius in the 1930's.
- Electrophoresis has been applied to analytical separation of different compounds like anions, cations, amino acids, vitamins, nucleic acids etc...

Definition:

Electrophoresis is a separation method based on the differential rate of migration of charged species in a buffer solution across which has been applied a dc electric current

Procedure:

- An electrophoretic separation is performed by injecting a small band of the sample into an aqueous buffer solution that is contained in a narrow tube or on a flat porous support medium such as paper or semisolid gel.
- A high dc potential is applied across the length of buffer by means of a pair of electrodes located at either end of buffer.
- This potential causes ions of the sample to migrate toward one or the other of the electrodes.
- The rate of migration of species depends upon its charge and also upon its size.
- Separation are then based upon differences in charge to size ratio for the various analytes in the sample
- The larger this ratio, the faster an ion migration in the electric field

Basics of electrophoretic separations:

- Separation of analytes achieved by differences in their velocity in an electric field
- The migration velocity v of an ion in centimeters per second is

$$v = \mu_e E \longrightarrow 1$$

μ_e = electrophoretic mobility

E = applied electric field

- The electrophoretic mobility is in turn proportional to the ionic charge on the analyte and inversely proportional to the frictional retarding process
- The ion mobility is given by the relationship shown below

$$\mu_e = \frac{\text{Electric Force } (F_E)}{\text{Fractional drag } (F_F)}$$

$$F_E = q E$$

where, q = charge on the ion

E = applied electric field

- The greater the charge on ion the more rapidly it migrates in a particular electric field

For spherical ion : $F_F = -6\pi\eta r v$

- When fractional drag and electric field experienced by ion are equal

$$qE = -6\pi\eta r v$$

Substituting this expression in equation 1

$$\mu_e = q / 6\pi\eta r$$

q = charge on ion

η = viscosity

r = ion radius

- For more irregular shaped solutes

$$\mu_e = \epsilon\zeta / 6\pi\eta$$

ϵ = dielectric constant

ζ = zeta-potential

- If two species differ either in charge or in frictional forces they experience in moving through the buffer, they will be separated from each other.
 - i. *Greater the charge on ion, higher its mobility.*
 - ii. *Smaller the ion, greater its mobility.*
- For ions of same charge, the smaller the ion, the smaller the frictional forces and faster rate of migration.
- The electric field acts only on ions

Types of electrophoresis

- *Capillary*
- *Slab*
- Native Polyacrylimide Gel Electrophoresis (PAGE)
- SDS-PAGE
- Paper

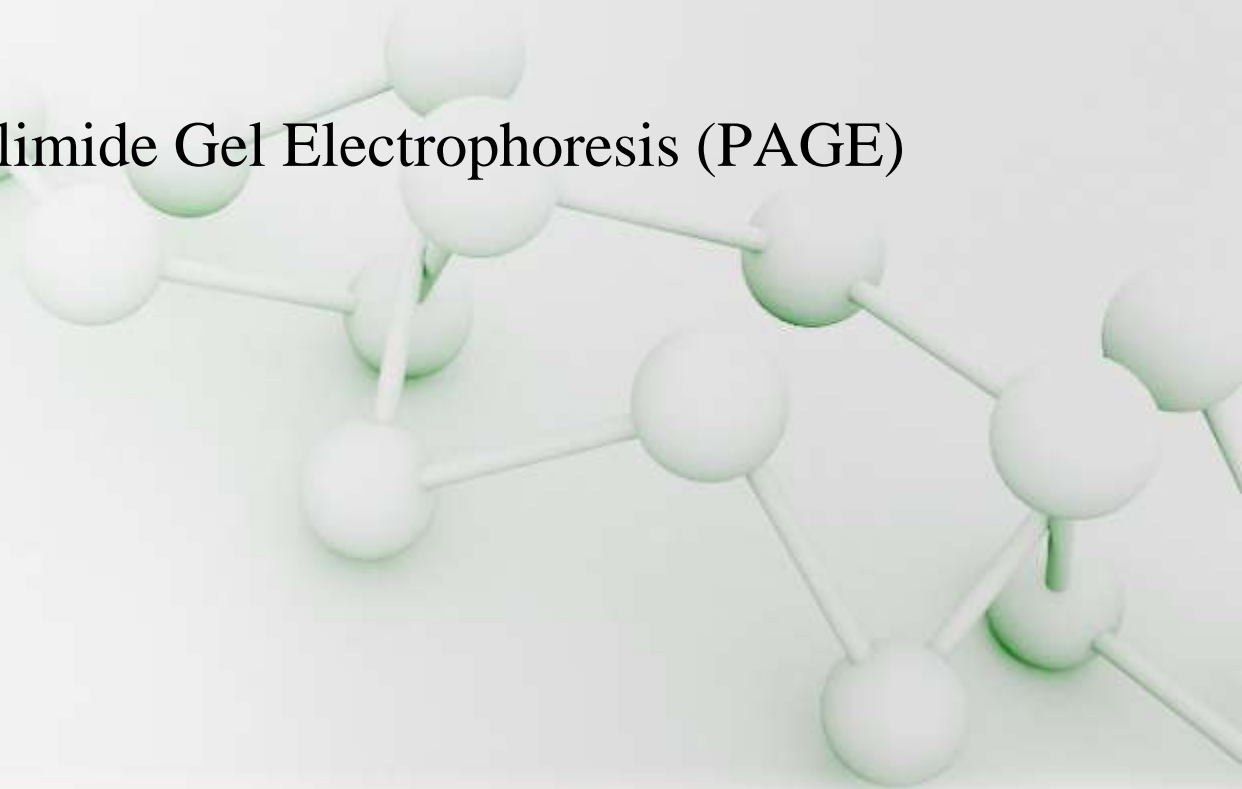

Slab electrophoresis:

- a. This is the classic method that has been used for many years to separate complex , high molecular weight species of biological and biochemical interest.
- b. Slab separations are carried out on a thin flat layer or slab of a porous semisolid gel containing an aqueous buffer solution within its pores.
- c. Ordinarily this slab has dimensions of few centimeters on a side and like a chromatographic thin layer plate, is capable of separating several samples simultaneously.
- d. Samples are introduced as spots or bands on the slab and a dc potential is applied across the slab for a fixed period.
- e. When the separations are judged complete, the current is discontinued and the separated species are visualized by staining.

Slab Gel Electrophoresis (SGE)

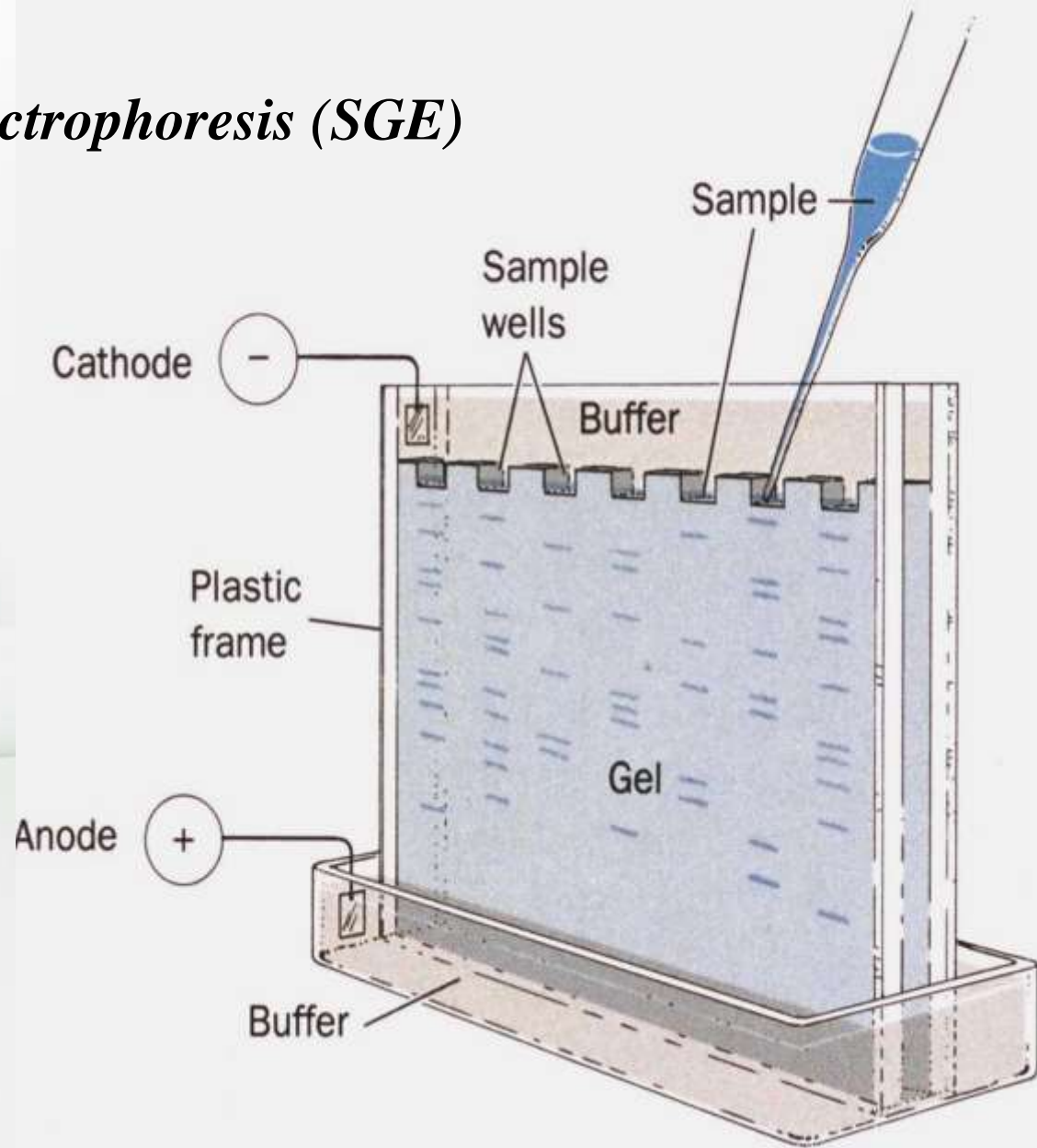
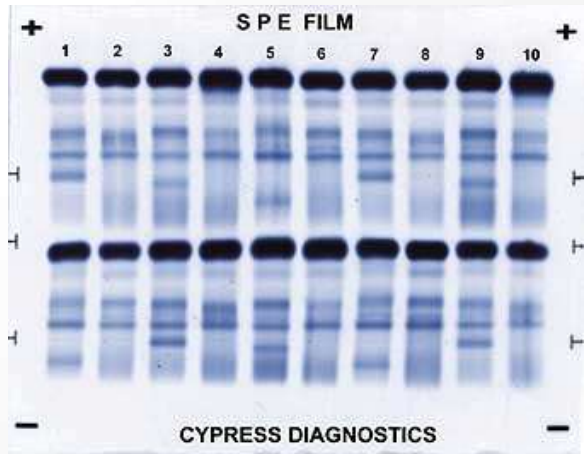

Advantages:

- Allowing for two dimensional analysis, and of running multiple samples simultaneously in the same gel
- For laboratories performing routine nucleic acid analysis and those employing antigenic controls, slab gels have become standard

Disadvantages:

- Does not yield very precise quantitative information
- Labor intensive
- Difficult to automate

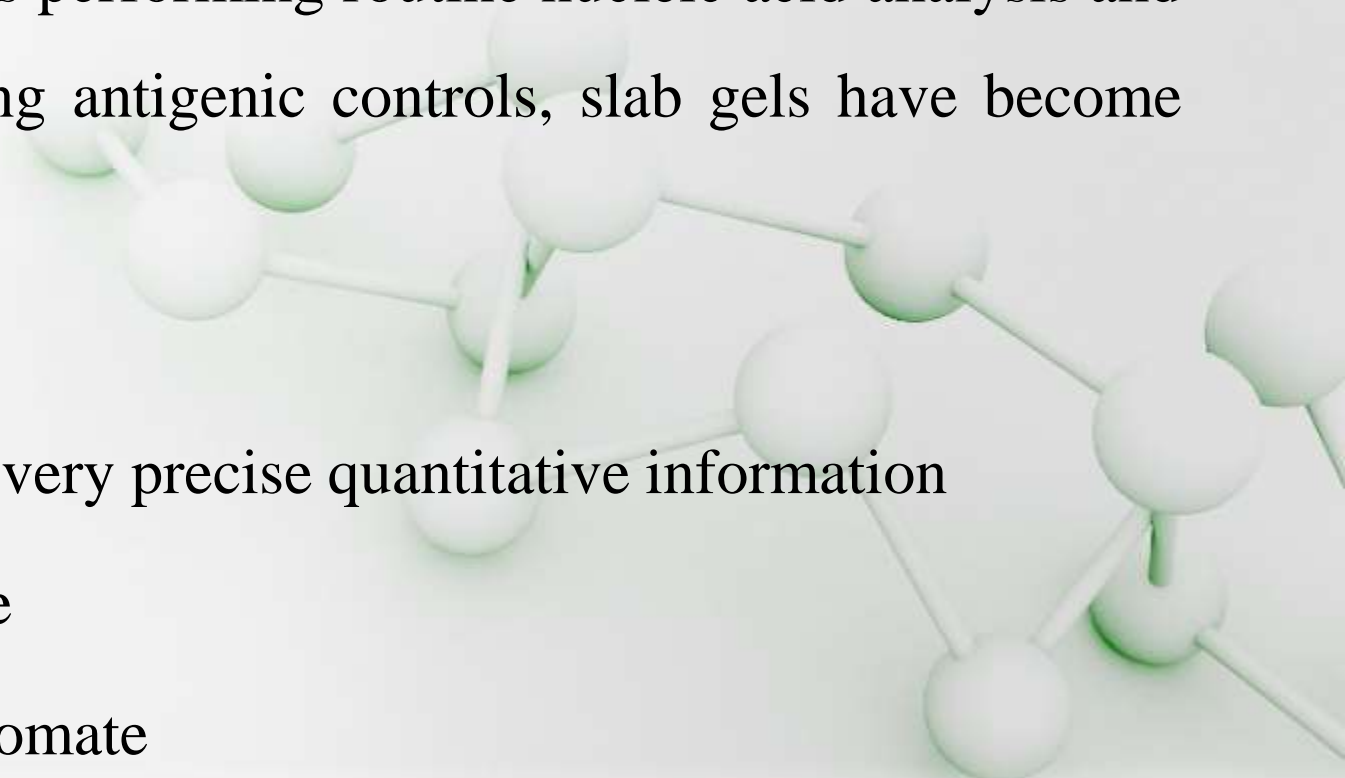

Capillary electrophoresis

- Capillary electrophoresis is the most rapidly expanding separation technique in pharmaceutical analysis and is a rival to HPLC in its general applicability
- A separation technique carried out in capillaries based solely on the differences in electrophoretic mobilities of charged species either in aqueous or non aqueous background electrolyte solutions

Advantages :

- Faster results and provides high resolution separation
- Offers new selectivity an alternative to HPLC
- Easy and predictable selectivity
- Small sample sizes
- Fast separations
- Quantitation
- Easily coupled to MS
- Different modes

Strengths :

- Potentially many times more efficient than HPLC in its separating power.
- Shorter analysis times than HPLC
- Cheaper columns than HPLC
- Negligible solvent consumption

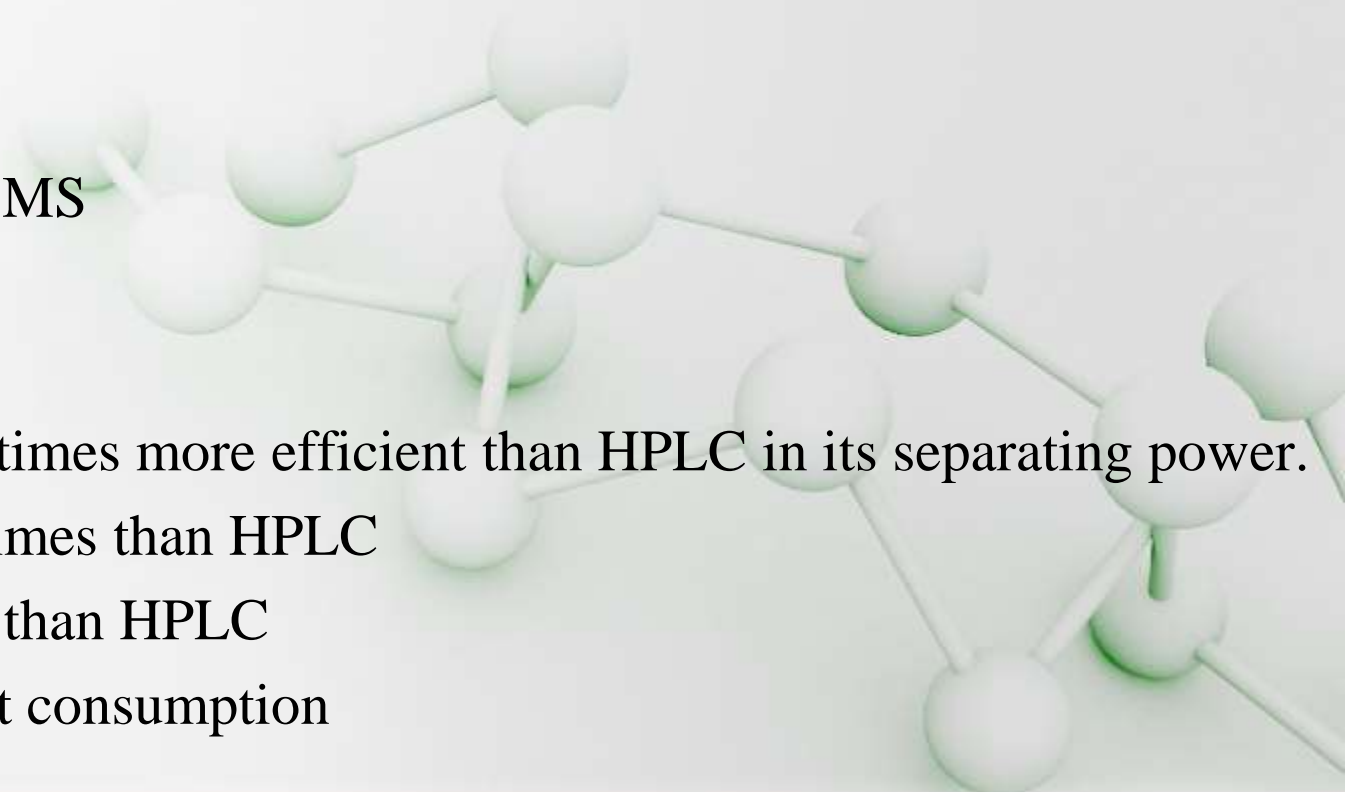

Migration rates and plate heights in capillary electrophoresis:

- An ion's migration velocity v depends upon the electric field strength
- The electric field in turn is determined by the magnitude of the applied potential (V in volts) and the length L over which it is applied. Thus velocity of an ion in an electric field

$$v = \mu_e E$$

$$E = V/L$$

$$v = \mu_e V/L$$

- This relationship indicates that high applied potentials are desirable to achieve rapid ionic migration and a rapid separation.

Plate heights in capillary electrophoresis

- Van-deemter equation

$$\mathbf{H=A+B/\mu+C\mu}$$

- In capillary electrophoresis, very narrow capillary tube is used.
- No eddy diffusion (A) as tube is open multipath is not observed.
- As single phase is involved for electrophoresis (there is no stationary phase) there is no mass transfer (C).
- So for electrophoresis only a longitudinal diffusion need be considered

$$\mathbf{H=B/\mu}$$

- Generally number of theoretical plates is given by

$$\mathbf{N = L/H}$$

Substitute $H = B/v = 2D/v$

$$v = \mu_e E = \mu_e V/L$$

$$N = L/B/v$$

$$N = L/2D \times \mu_e V/L$$

- For electrophoresis that the plate count is given by

$$\mathbf{N = \mu_e V/2D}$$

Where,

N = No of theoretical plates

μ_e = Electrophoretic mobility

V = Applied potential

D = Diffusion coefficient of solute

v = Migration velocity

- Because resolution increases as the plate count increases, it is desirable to use high applied potential in order to achieve high resolution separations

Electro osmotic Flow (EOF)

- Relative movement of a liquid to a fixed charged surface caused by an electric field.
- When a high potential is applied across a capillary tube containing buffer solution ,electro osmotic flow usually occurs, in which the solvent migrates toward cathode or anode

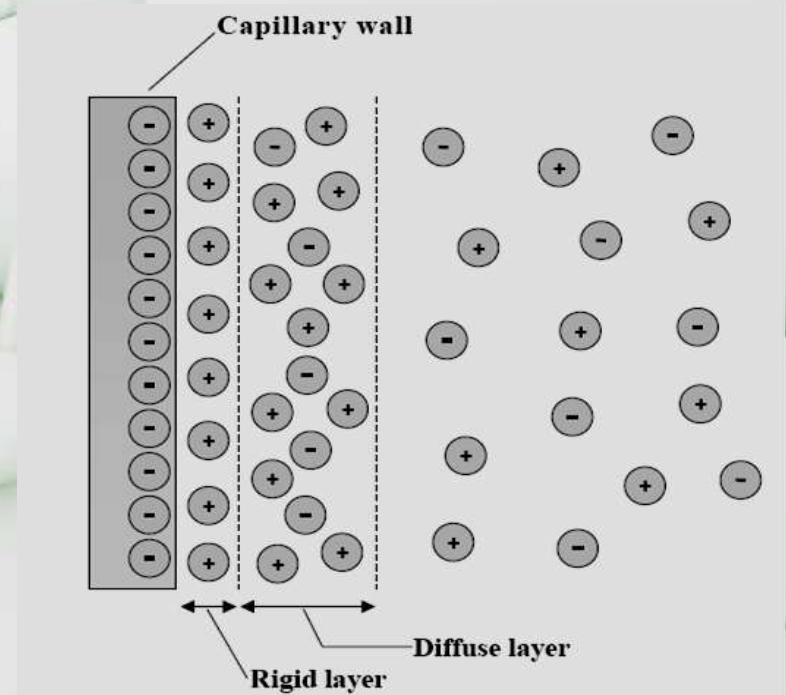
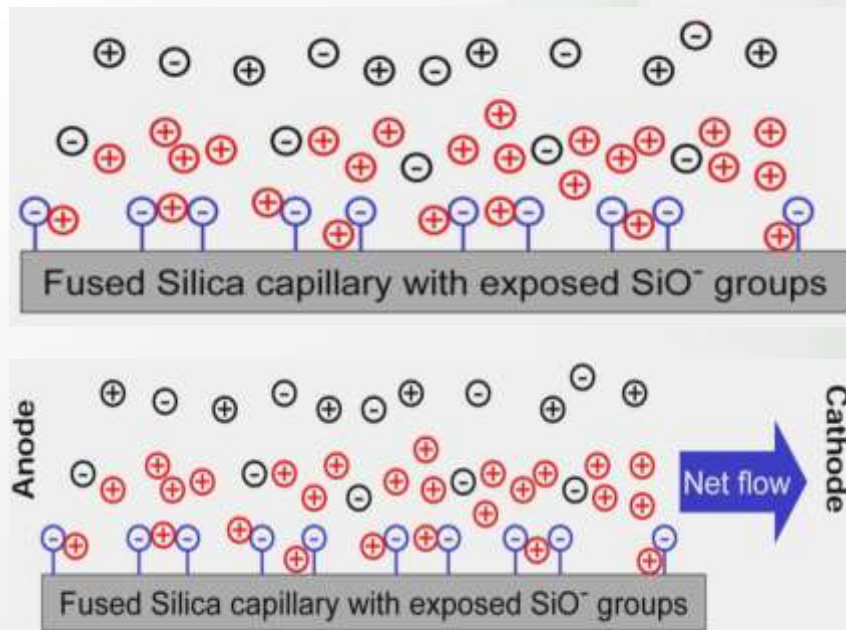

- The inside wall of the capillary is covered by silanol groups (SiOH) that are deprotonated (SiO^-) at $\text{pH} > 2$
- SiO^- attracts cations to the inside wall of the capillary
- The distribution of charge at the surface is described by the Stern double-layer model and results in the zeta potential
- It would seem that CE separations would start in the middle and separate ions in two linear directions
- Excess cations in the diffuse Stern double-layer flow towards the cathode, exceeding the opposite flow towards the anode
- Net flow occurs as solvated cations drag along the solution

Electro osmotic mobility:

$$v = \mu_{eo} E = \left(\frac{\epsilon_0 \epsilon \zeta}{4\pi \eta} \right) E$$

$$\mu_{eo} = \frac{\epsilon_0 \epsilon \zeta}{4\pi \eta}$$

Where:

v = Electro osmotic mobility

ϵ_0 = Dielectric constant of a vacuum

ϵ = Dielectric constant of the buffer

ζ = Zeta potential

E = Electric field

- Key factors that affect electro osmotic mobility:
 - i. dielectric constant and*
 - ii. viscosity of buffer (controls double-layer compression)*
- EOF can be quenched by protection of silanols or low pH

Electro osmotic Flow Profile

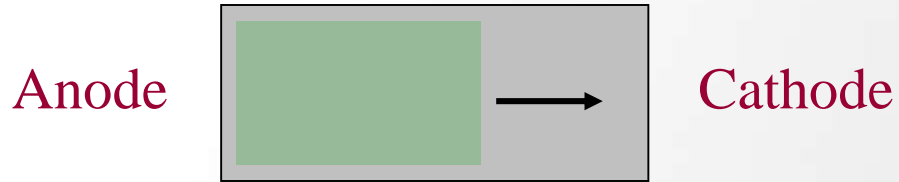

Electro osmotic flow profile

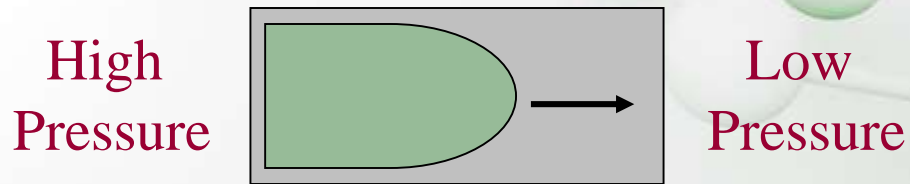

Hydrodynamic flow profile

- Driving force (charge along capillary wall)
- No pressure drop is encountered
- Flow velocity is uniform across the capillary
- Electro driven flow **flat** flow profile

✓ Frictional forces at the column walls cause a pressure drop across the column

✓ Pressure driven flow (laminar flow) **Parabolic** flow

- **Result:** Electro osmotic flow does not contribute significantly to band broadening like pressure-driven flow in LC and related techniques

- It is possible to reverse the direction of the normal electro osmotic flow by adding a cationic surfactant to the buffer. The surfactant adsorbs on the capillary wall and makes the wall positively charged.

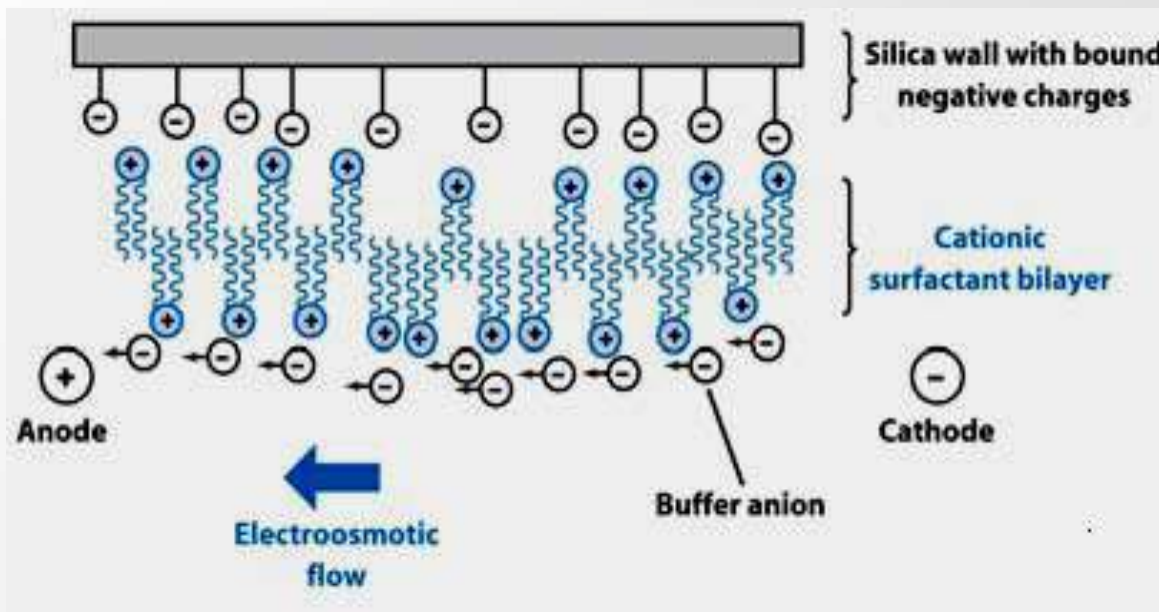

Electro osmotic flow can be eliminated by coating the inside capillary wall with a reagent like trimethyl chlorosilane to eliminate the surface silanol groups.

Control of EOF

- **Electric field** EOF proportional change
- **Buffer pH** ↓_{se} at low pH, ↑_{se} at high pH
- **Ionic strength and buffer concentration** Decrease ζ -potential and EOF
- **Temperature** Changes η 3% per °C
- **Organic modifier** Decrease ζ -potential and η
- **Surfactant** Adsorbs to capillary wall
- **Neutral hydrophilic polymers** Adsorbs to capillary wall
- **Covalent coating** Stability

Electrophoresis and Electro osmosis

- Combining the two effects for migration velocity of an ion (also applies to neutrals, but with $\mu_{ep} = 0$):

$$v = (\mu_{ep} + \mu_{eo})E = (\mu_{ep} + \mu_{eo})\frac{V}{L}$$

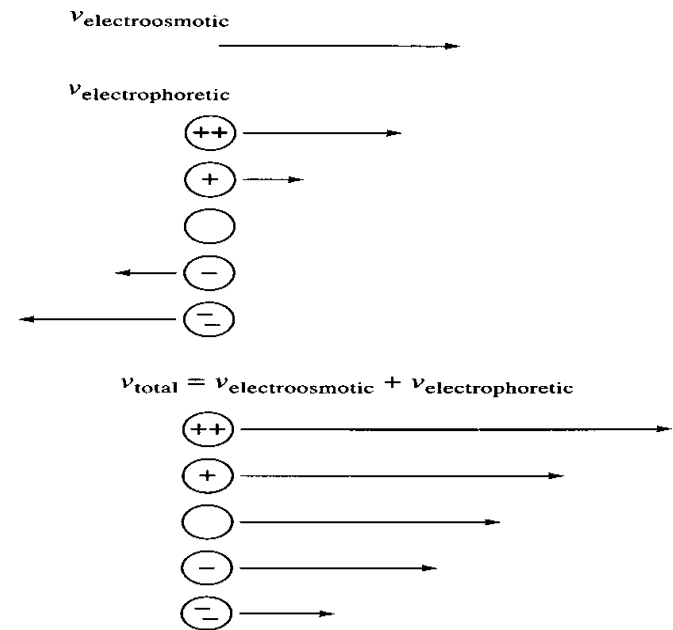
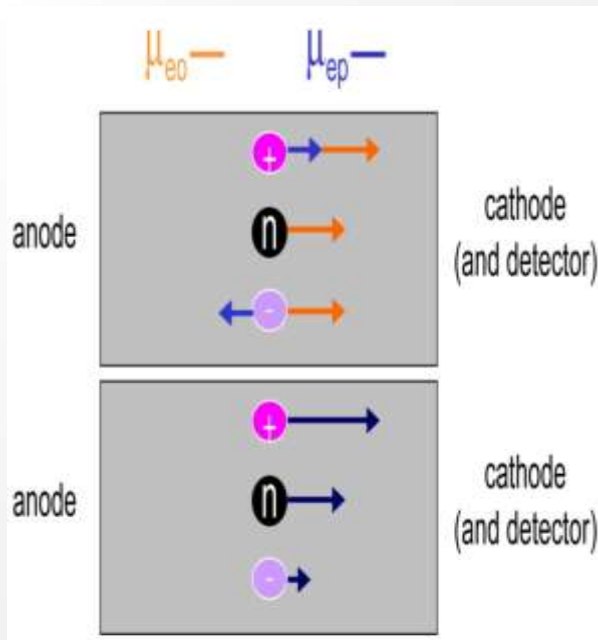

A pictorial representation of the combined effect in a capillary

Instrumentation

1. Sample Introduction

Electro kinetic Injection

Hydrodynamic injection

2. Detection

Absorbance Methods

Indirect Detection

Fluorescence Detection

Electrochemical Detection

Mass Spectrometric Detection

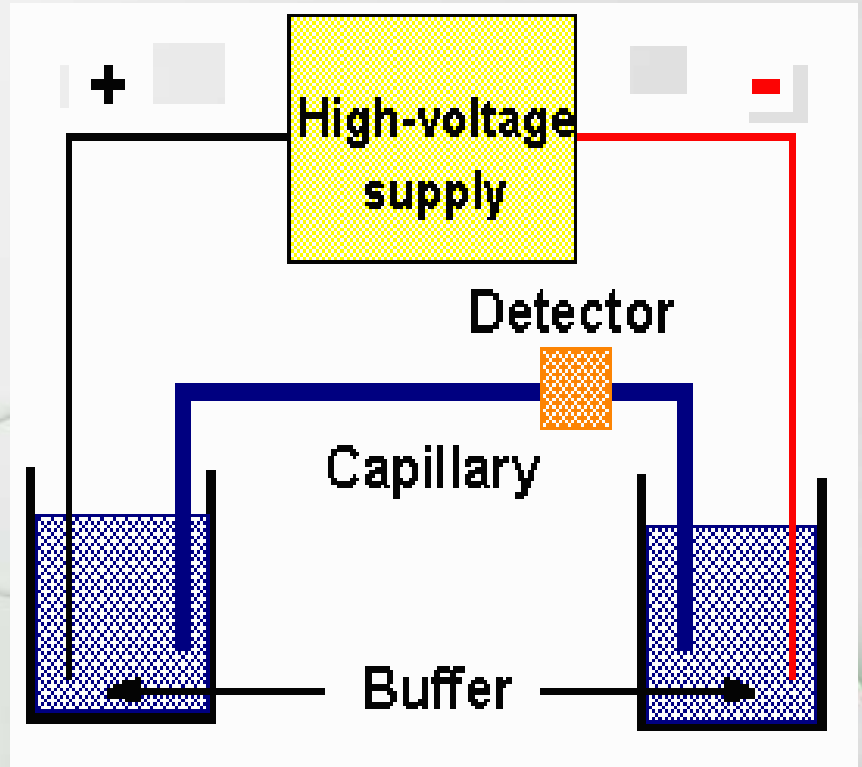

Cross-section of a capillary:

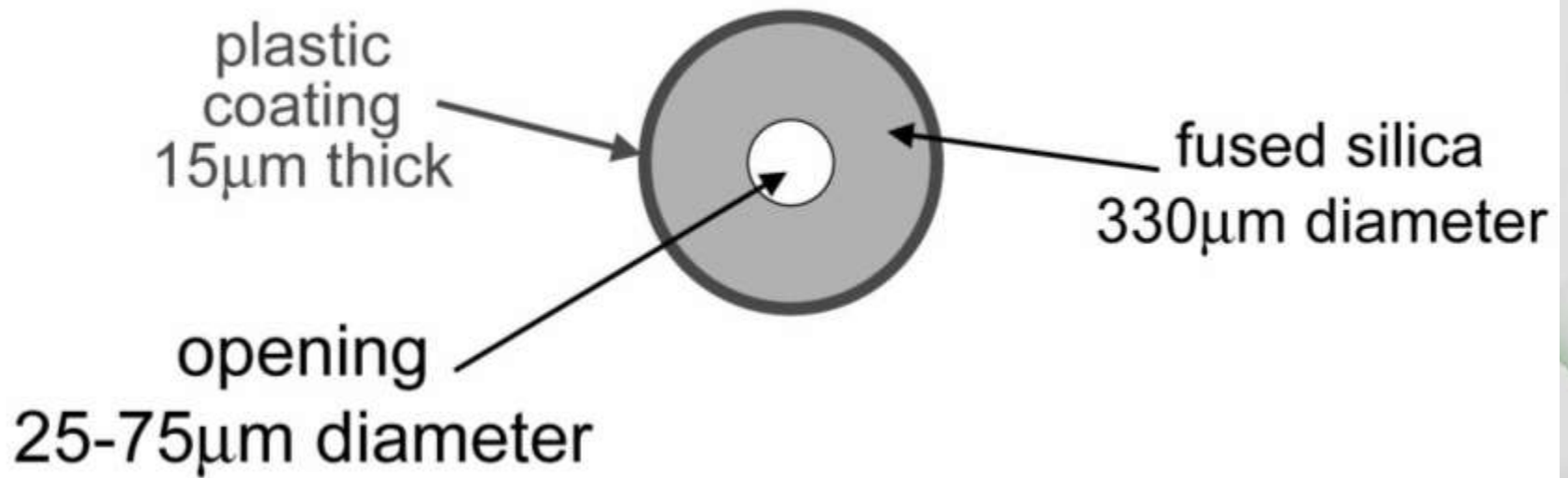

Sample introduction

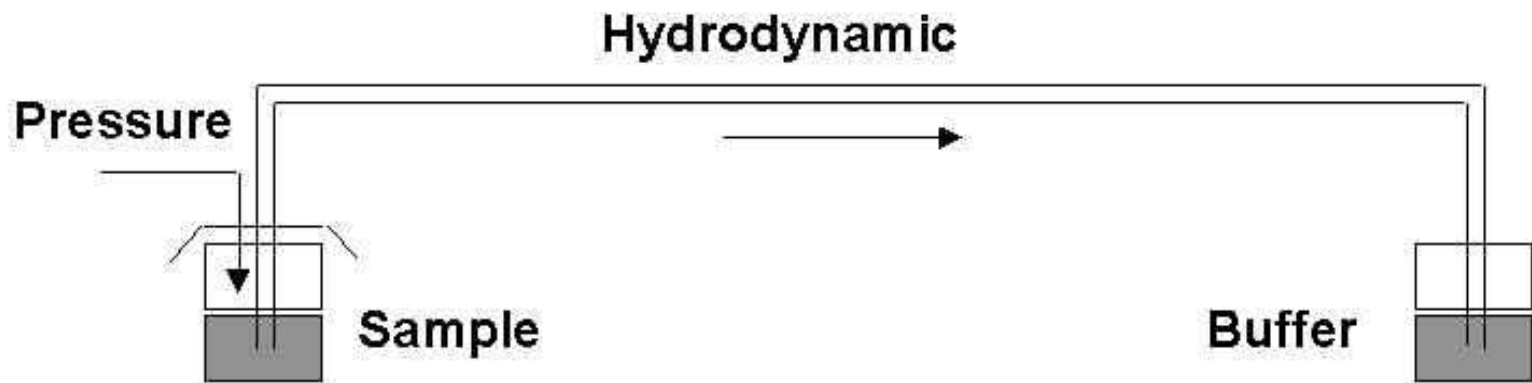
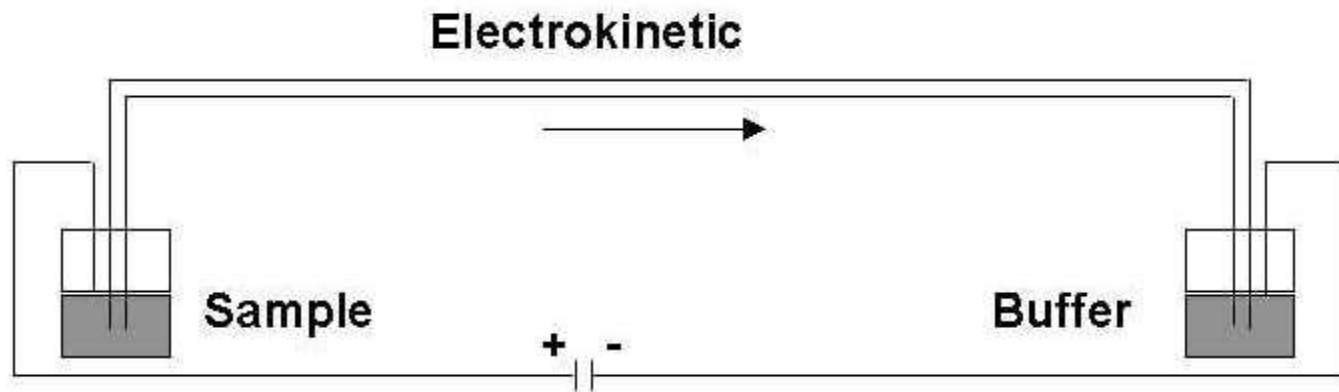

- Electrokinetic injection technique discriminates by injecting larger amounts of the more mobile ions relative to the slower moving ions.
- Pressure injection does not discriminate due to ion mobility, but can be used in gel-filled capillaries.
- For both electrokinetic injection and pressure injection the volume injected is controlled by the duration of the injection.

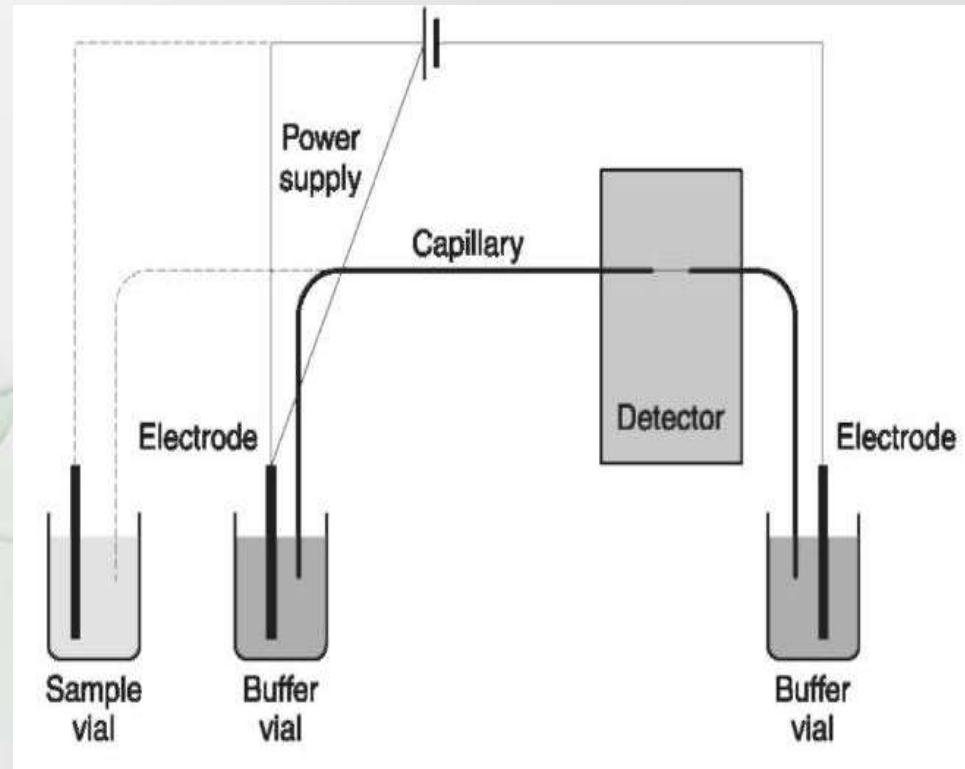

Detectors:

- Detectors are similar in design and function to those described for HPLC.
- In capillary electrophoresis analyte bands pass through the detector at different rates, results in that peak areas are somewhat dependent upon retention times.
- Detectors are placed at the cathode since under common conditions, all species are driven in this direction by EOF.
- Detectors similar to those used in LC, typically UV absorption, fluorescence, and MS.

The general layout of an electropherogram

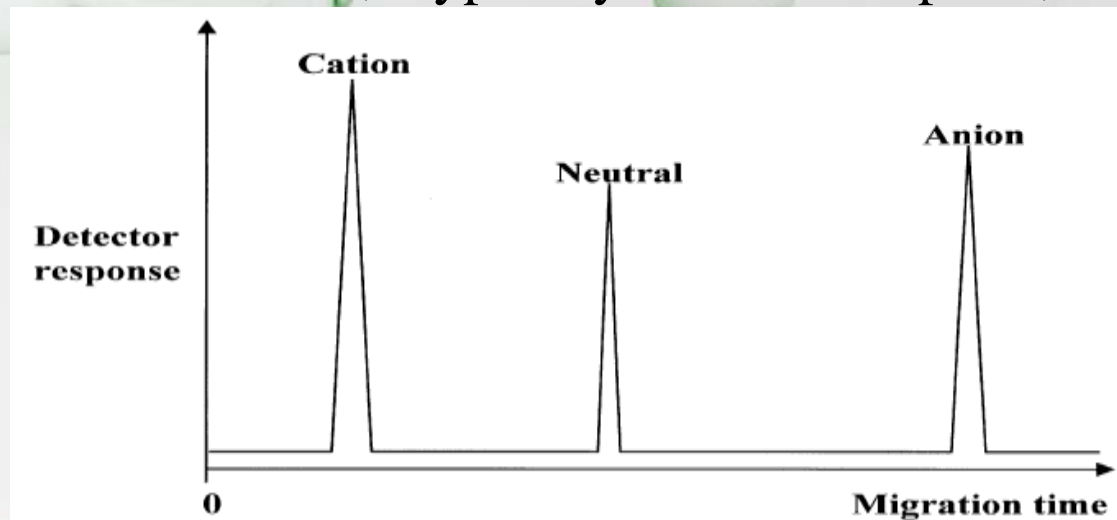

- Detection is performed **on-column**
- A section of the protective polyamide coating is removed from the exterior of the capillary by burning, dissolution, or scrapping.
- In these systems, this section of the capillary itself is used as the detection cell.
- The pathlength of the detection cell in capillary electrophoresis ($\sim 50 \mu\text{m}$) is far less than that of a traditional UV cell ($\sim 1 \text{ cm}$).
- According to the **Beer-Lambert law**, the sensitivity of the detector is proportional to the path length of the cell.
- In order to improve the sensitivity of absorbance measurements, several techniques have been suggested for increasing the pathlength of the measurements.

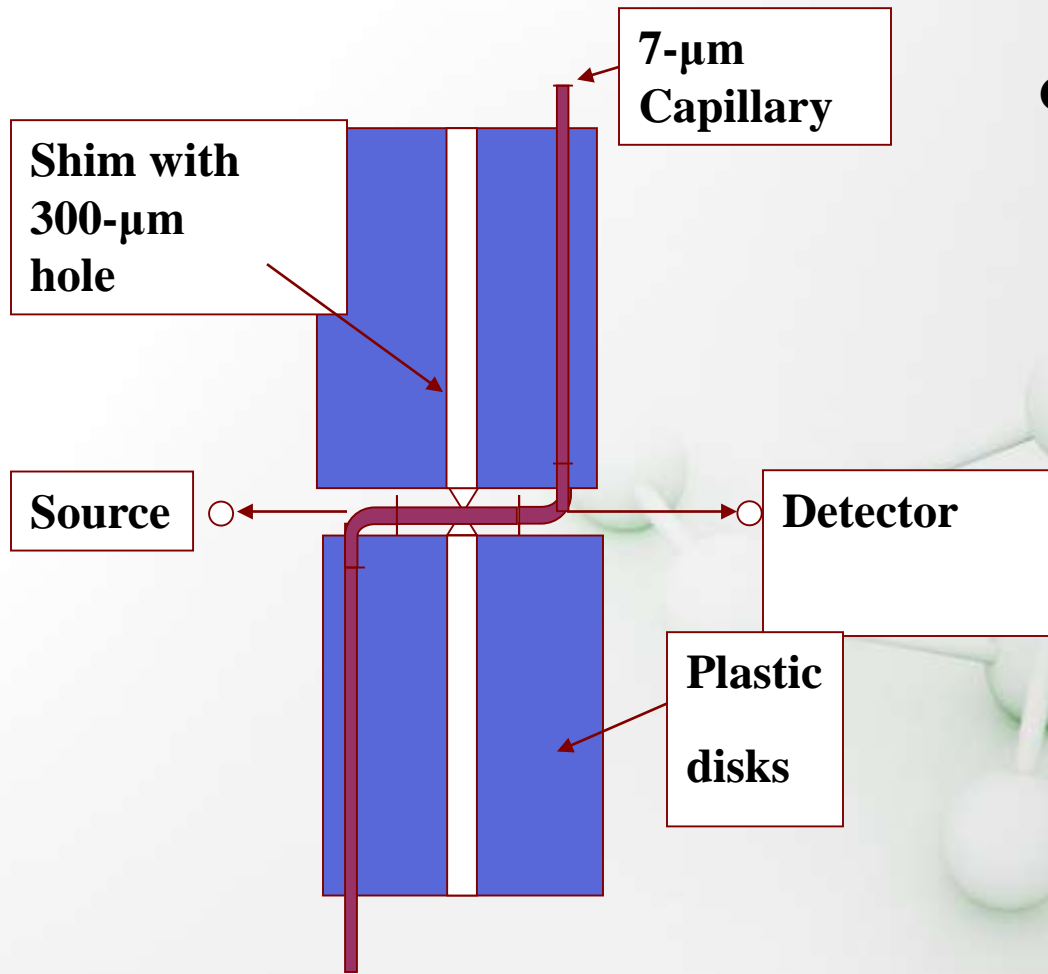

The 3-mm z cell

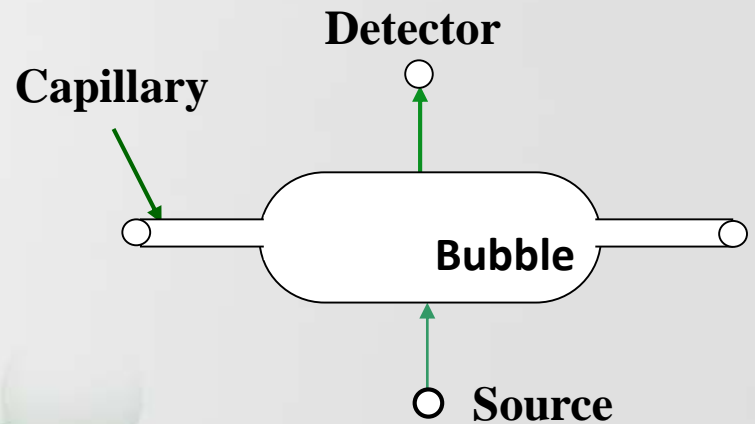

The 150 μm bubble cell



The multireflection cell

Indirect detection:

- Indirect absorbance detection has been used for detection of species that are difficult to detect because of low absorptivities.
- In this method a UV absorbing species is added to the buffer, producing a constant UV signal.
- Arrival of the poorly absorbing analyte yields a drop in absorbance.
- The analyte is then determined from the decrease in absorbance.

CE electropherogram

- Like a chromatogram, it is a plot of the **time from injection** on the x axis vs. **the detector signal** on the y axis.

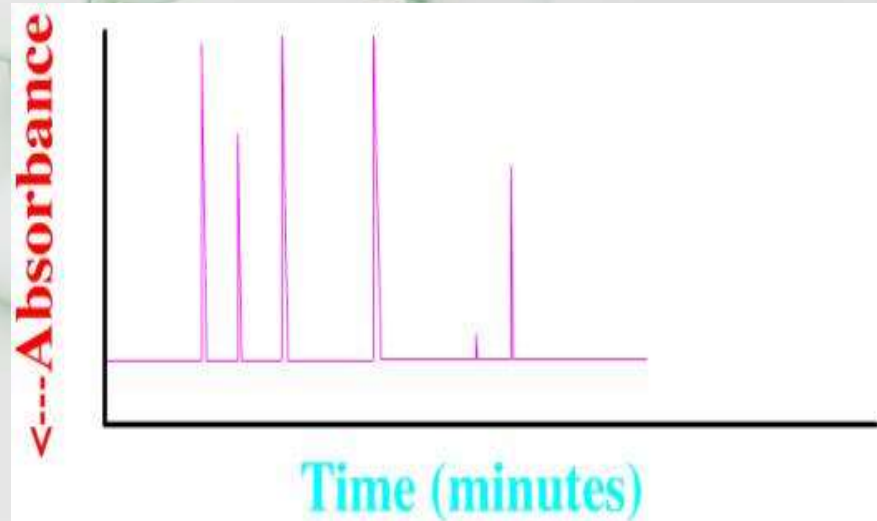

Fluorescence detection:

- Fluorescence detection can also be used in capillary electrophoresis for samples that naturally fluoresce or are chemically modified to contain fluorescent tags.
- This mode of detection offers high sensitivity and improved selectivity for these samples, but cannot be utilized for samples that do not fluoresce.
- Laser -based instrumentation is preferred in order to focus the excitation radiation on the small capillary.
- Laser -induced fluorescence has been used in CE systems with detection limits as low as 10^{-18} to 10^{-21} mol.
- The sensitivity of the technique is attributed to the high intensity of the incident light and the ability to accurately focus the light on the capillary

Mass spectrometric detection

- In order to obtain the identity of sample components capillary electrophoresis can be directly coupled with mass spectrometers.

- Used for determination of large molecules such as DNA fragments, proteins peptides and etc...

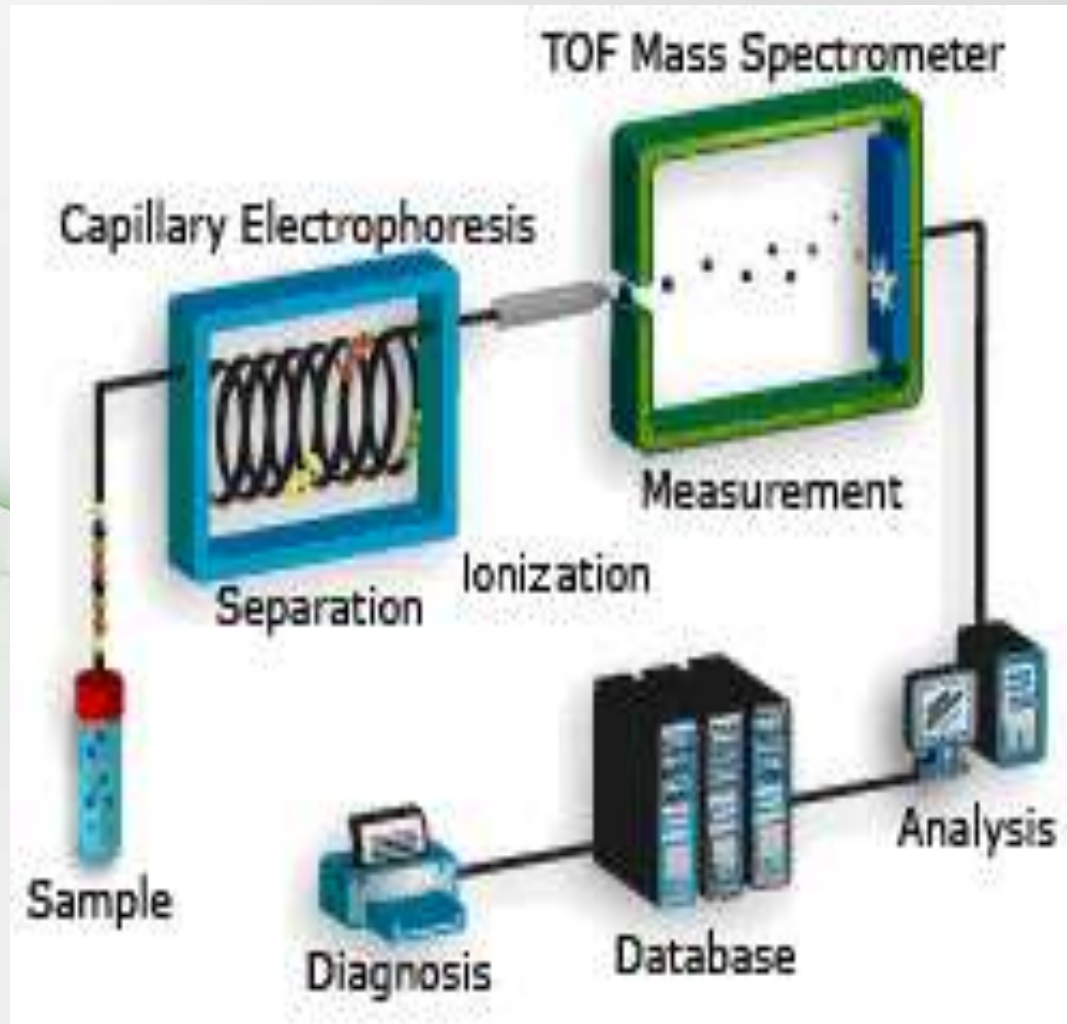

Modes of Capillary Electrophoresis

- 1) Capillary Zone Electrophoresis
- 2) Capillary Gel Electrophoresis
- 3) Capillary Isotachopheresis
- 4) Capillary Isoelectric Focusing

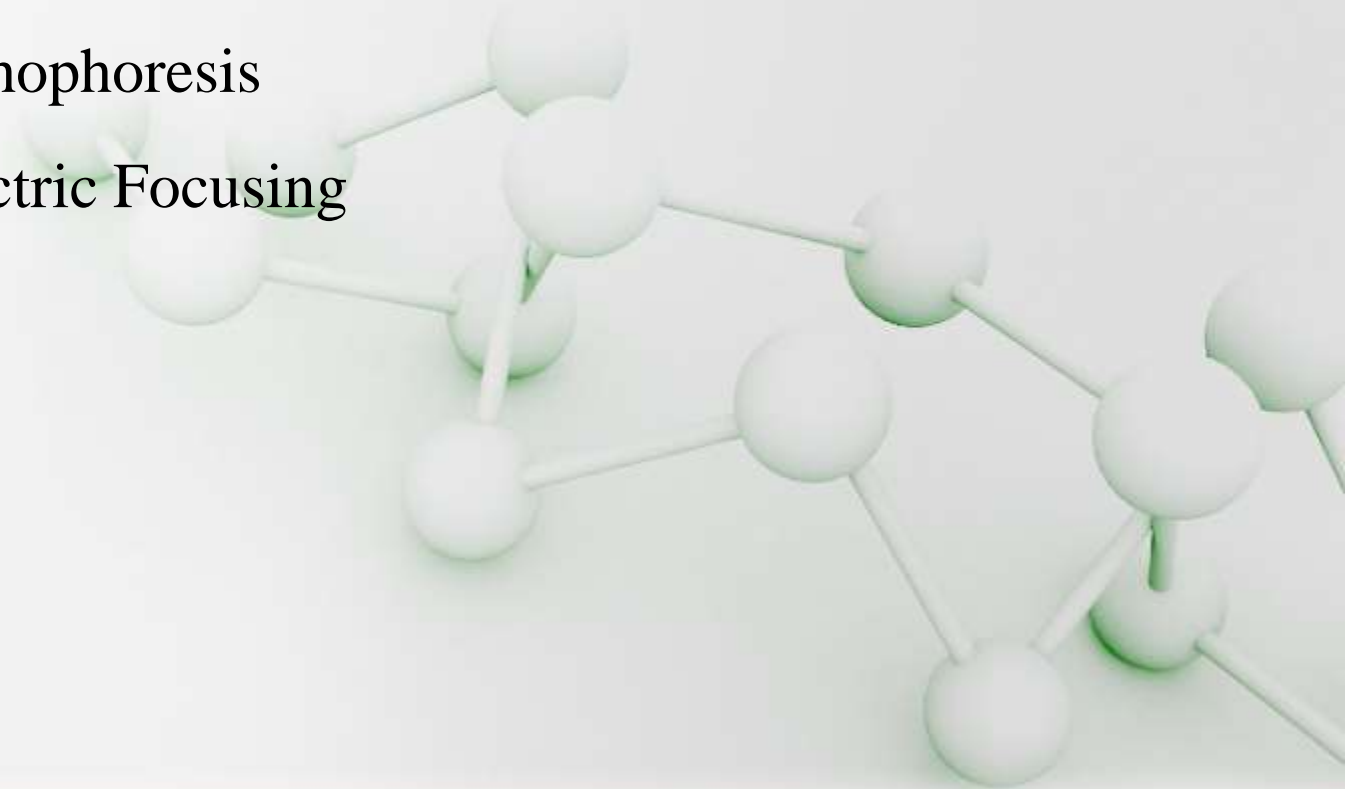

Capillary zone electrophoresis

- **CZE** also known as free-solution CE (FSCE), is the simplest form of CE .
- Fundamental to CZE are homogeneity of the buffer solution and constant field strength throughout the length of the capillary.
- The separation mechanism is based on difference in the charge-to-mass ratio of the analytes.
- CZE analytes move in the EOF but separate into bands because of differences in their electrophoretic mobilities, μ .

Applications:

- A variety of small synthetic herbicides ,pesticides ,and pharmaceuticals that are ionic have been separated and analyzed by CZE.
- Proteins ,amino acids, and carbohydrates have all been separated in minimum times by CZE.

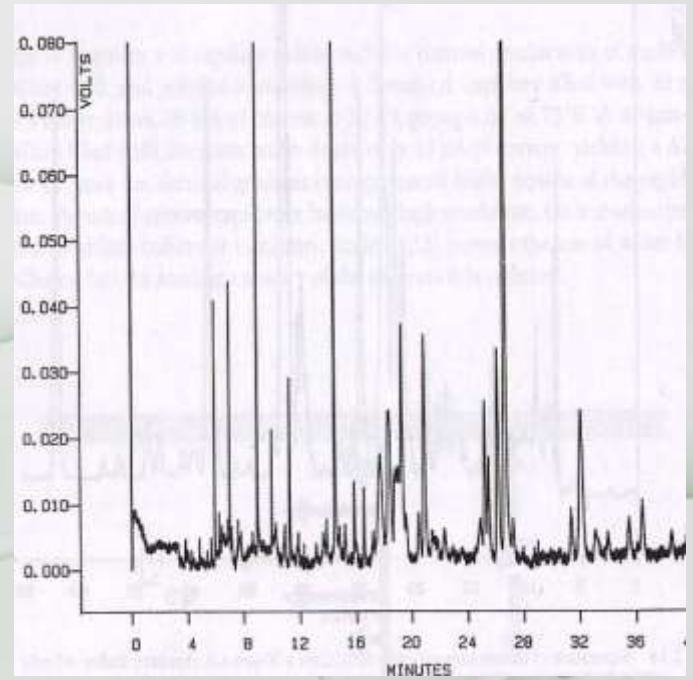
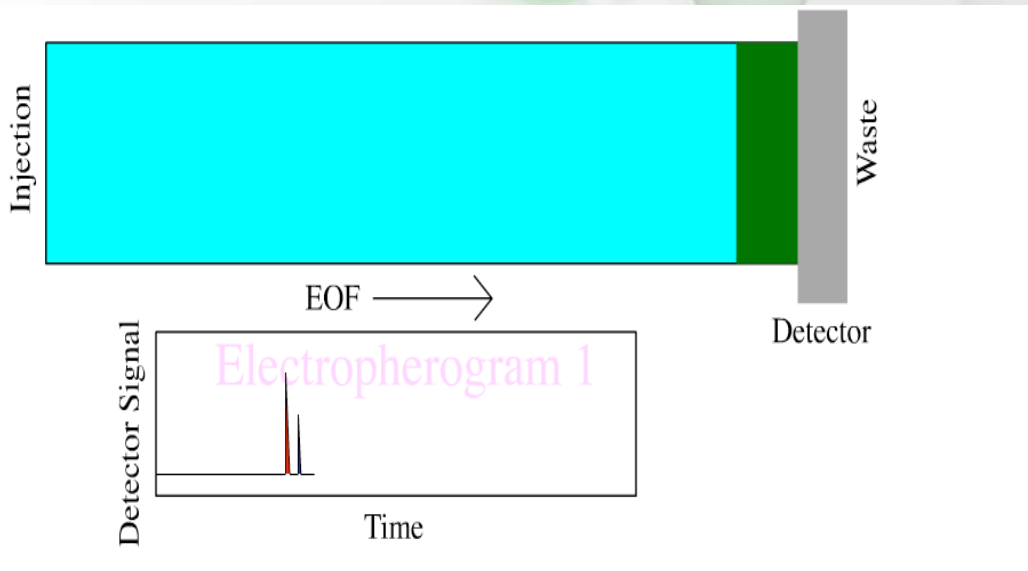
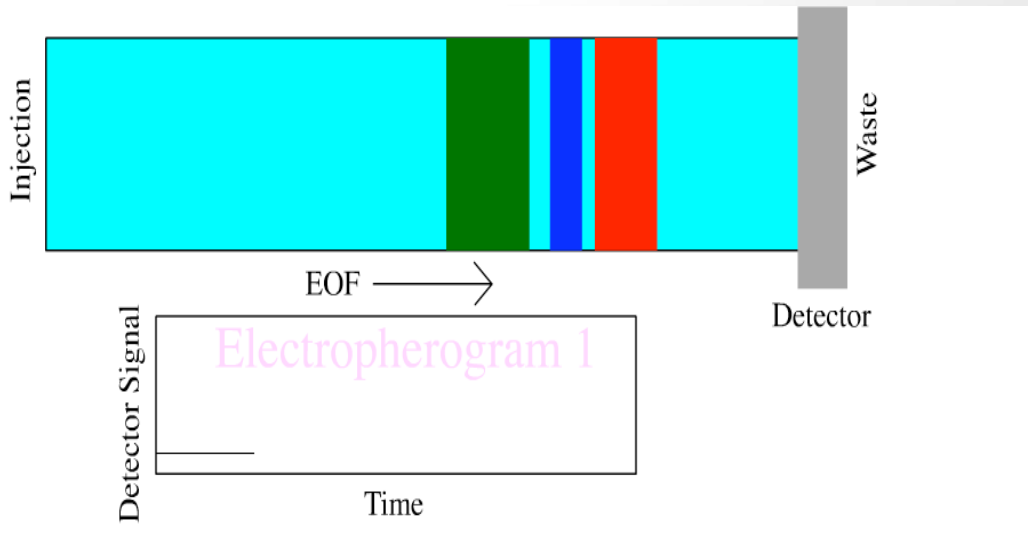

Capillary Gel Electrophoresis (CGE)

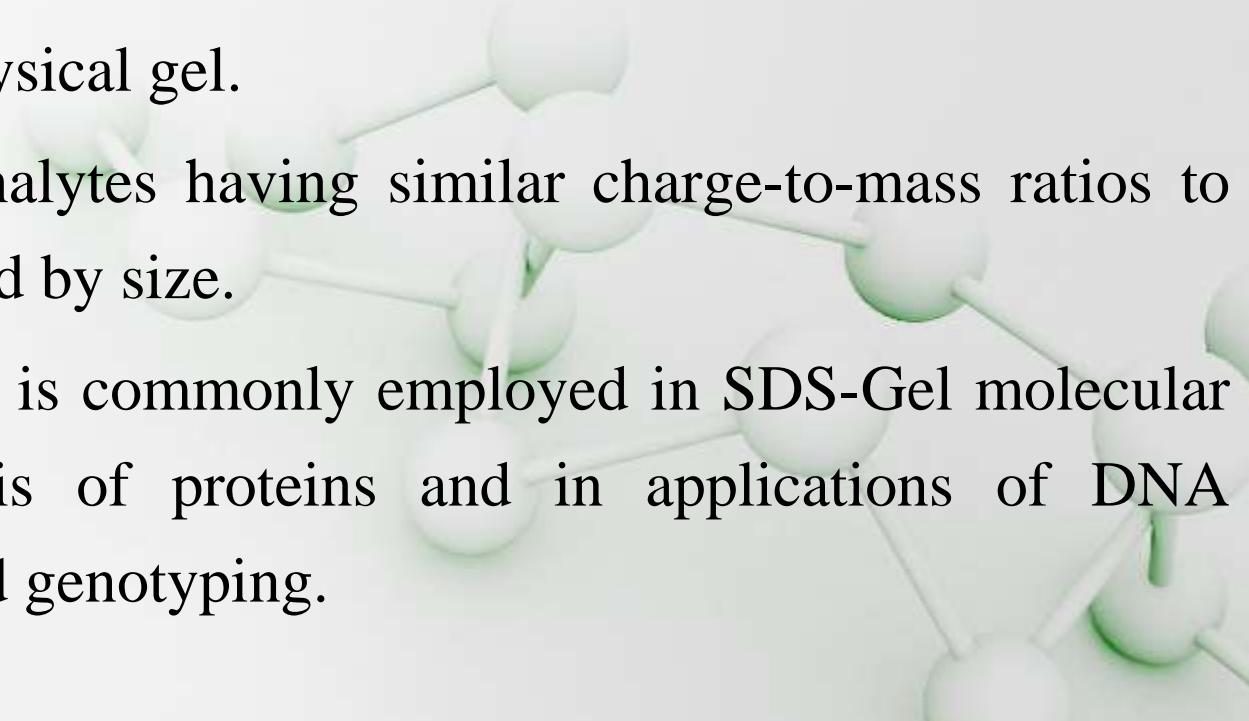
- **Capillary Gel Electrophoresis (CGE)** is the adaptation of traditional gel electrophoresis into the capillary using polymers in solution to create a molecular sieve also known as replaceable physical gel.
 - This allows analytes having similar charge-to-mass ratios to also be resolved by size.
 - This technique is commonly employed in SDS-Gel molecular weight analysis of proteins and in applications of DNA sequencing and genotyping.
- 

Capillary Isoelectric Focusing (CIEF)

- **Capillary Isoelectric Focusing (CIEF)** allows amphoteric molecules, such as proteins, to be separated by electrophoresis in a pH gradient generated between the cathode and anode.
- A solute will migrate to a point where its net charge is zero. At the solute's isoelectric point (pI), migration stops and the sample is focused into a tight zone.
- In CIEF, once a solute has focused at its pI, the zone is mobilized past the detector by either pressure or chemical means. This technique is commonly employed in protein characterization as a mechanism to determine a protein's isoelectric point.

Separation of protein molecules by isoelectric focussing

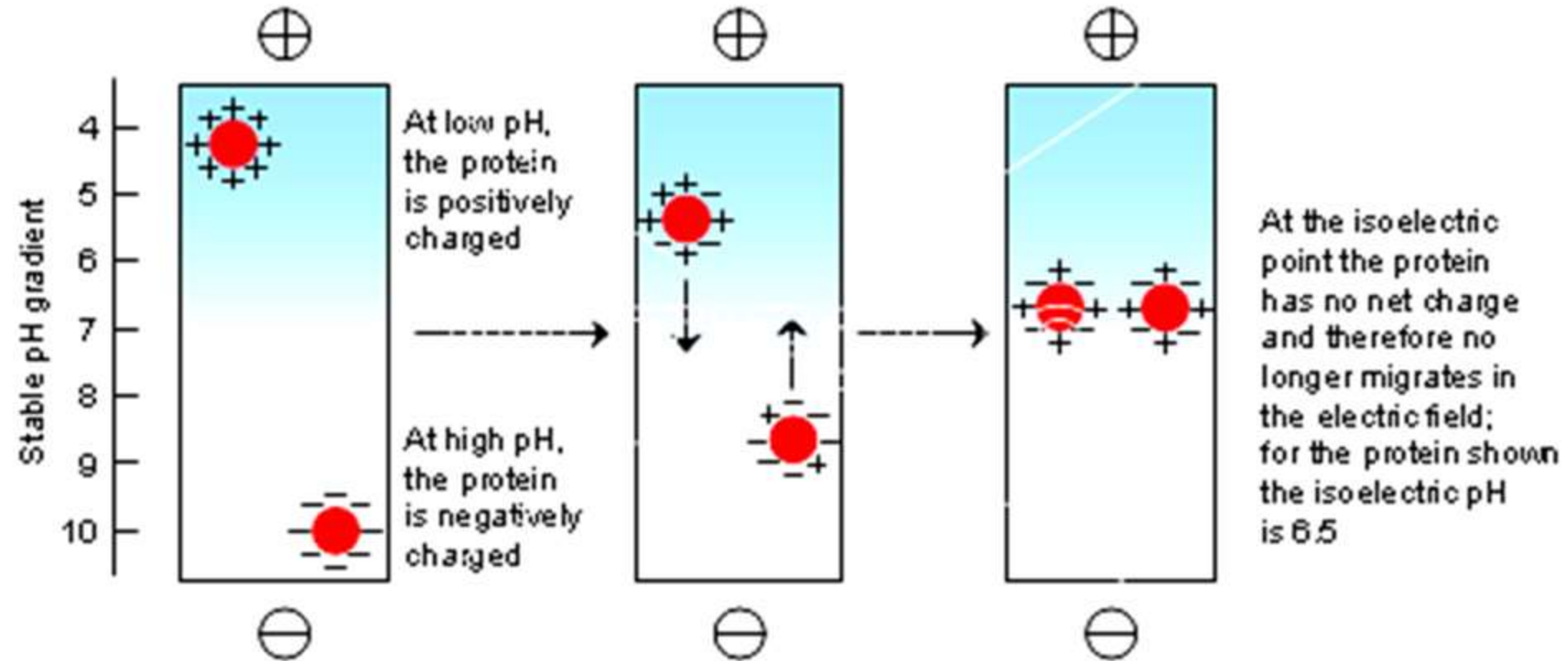

Capillary Isoelectric Focusing (CIEF)

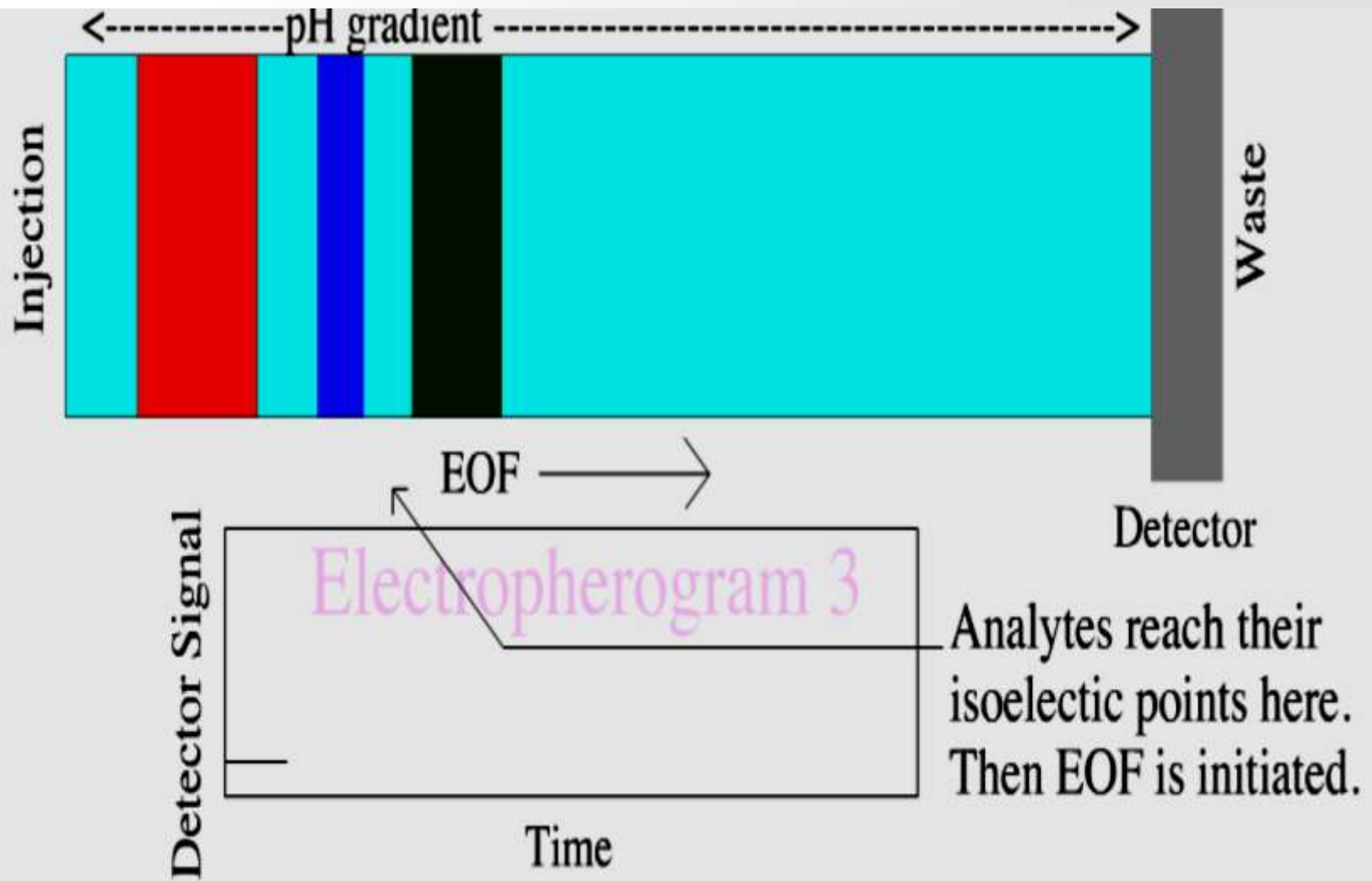

Capillary Isotachophoresis (CITP)

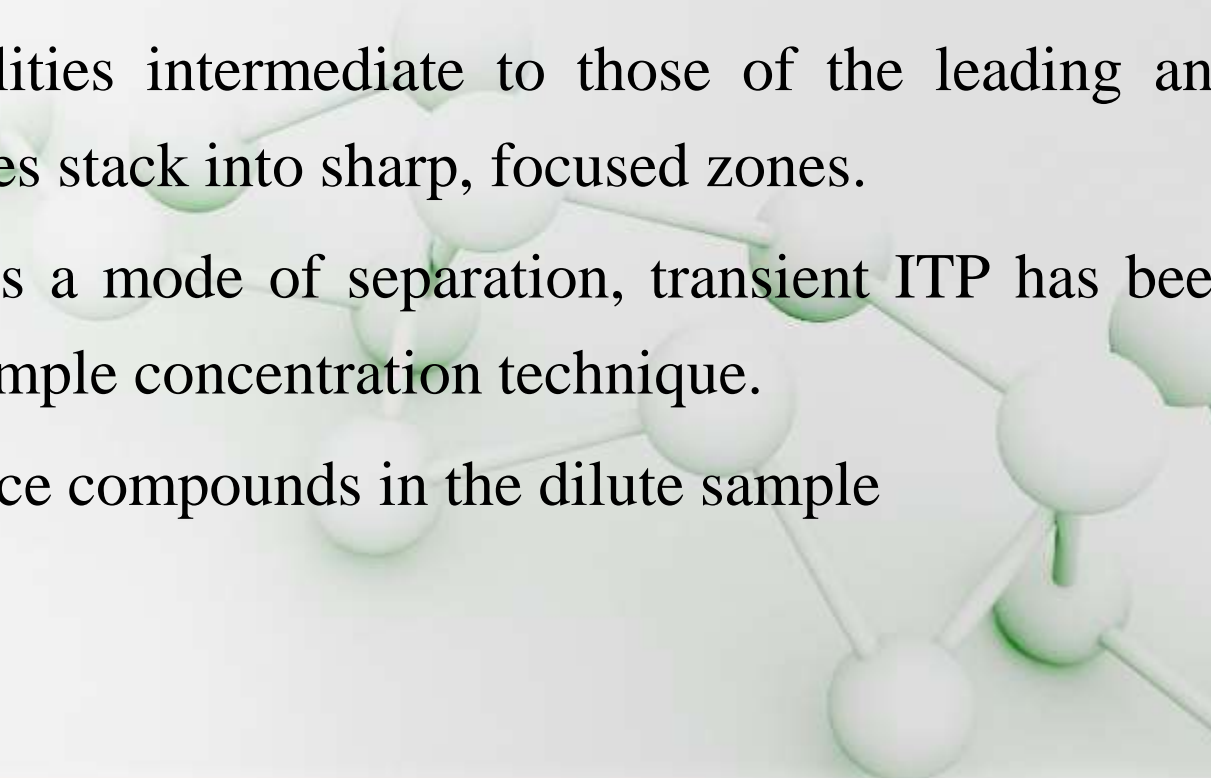
- Capillary Isotachophoresis is a focusing technique based on the migration of the sample components between leading and terminating electrolytes.
 - Solutes having mobilities intermediate to those of the leading and terminating electrolytes stack into sharp, focused zones.
 - Although it is used as a mode of separation, transient ITP has been used primarily as a sample concentration technique.
 - To concentrate the trace compounds in the dilute sample
- 

Capillary Isotachopheresis (CITP)

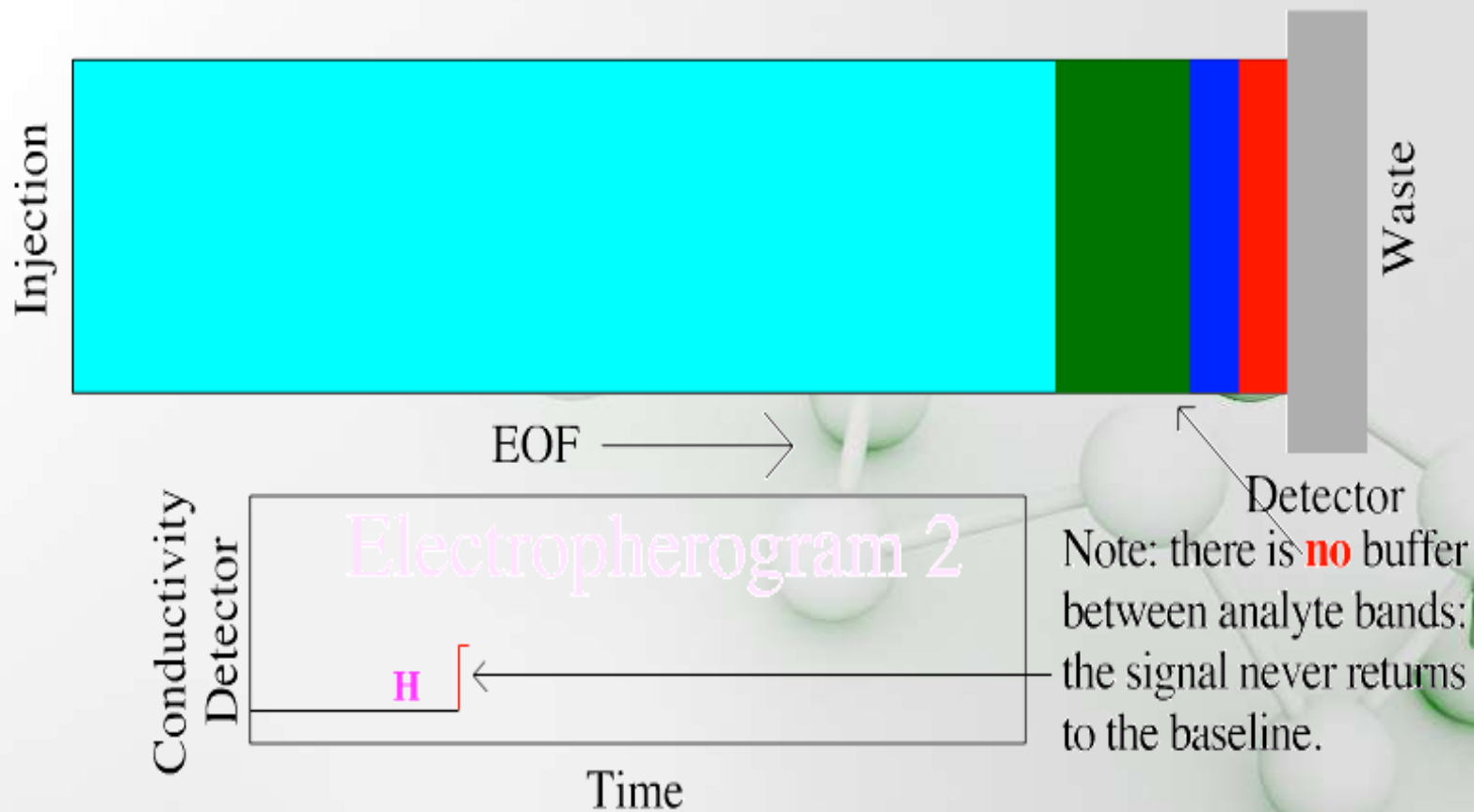

Applications

- **Pharmaceutical:** Reaction intermediates, purity validation, stability, final product testing, ion analysis, counter-ions (includes low MW, charged and neutrals, chirals)
- **Bioscience:** Peptides, proteins, DNA, carbohydrates
- **Foods:** Inorganic cations/anions, organic acids, amino acids, carbohydrates
- **Chemical:** Pesticides, PAHs, inorganic ions, transition metals, surfactants, dyes, polymers
- **Forensic:** Drugs of abuse, explosive residue, gun powder residue

Applications of CE in pharmaceutical analysis

- CE has been heavily studied within the pharmaceutical industry as an alternative to LC in various situations
- Separation of atenolol and related impurities predominantly on the basis of charge
- Separation predominantly on the basis of ionic radius
- Analysis of non-steroidal anti-inflammatory drugs by CE and separation of anions on the basis of ionic radius
- Separation of peptides
- The areas of pharmaceutical analysis covered are enantiomer separation, analysis of small molecules such as amino acids or drug counter-ions, pharmaceutical assay,, and physiochemical measurements such as log P and pKa of compounds.

- The vast applications of electrophoresis are most evident in the health or medical industry, including antibiotic and vaccine analysis.
- Protein and DNA analysis are also important electrophoresis applications.
- Then through electrophoresis, the amount of proteins in your blood or in your urine is measured and compared to established normal values--lower or higher than the normal levels usually indicates a disease.
- There are several vaccines that have been purified, processed and analyzed through electrophoresis, such as the influenza vaccine, hepatitis vaccine and polio vaccine.
- With electrophoresis, experts are not only able to synthesize new antibiotics but are also able to analyze which types of bacteria are antibiotic-resistant.
- Through electrophoresis, specific DNA sequences can be analyzed, isolated and cloned.
- The analyzed DNA may be used in forensic investigations and paternity tests

- During capillary electrophoresis, the products of the cycle sequencing reaction are injected electro kinetically into capillaries filled with polymer. High voltage is applied so that the negatively charged DNA fragments move through the polymer in the capillaries toward the positive electrode.

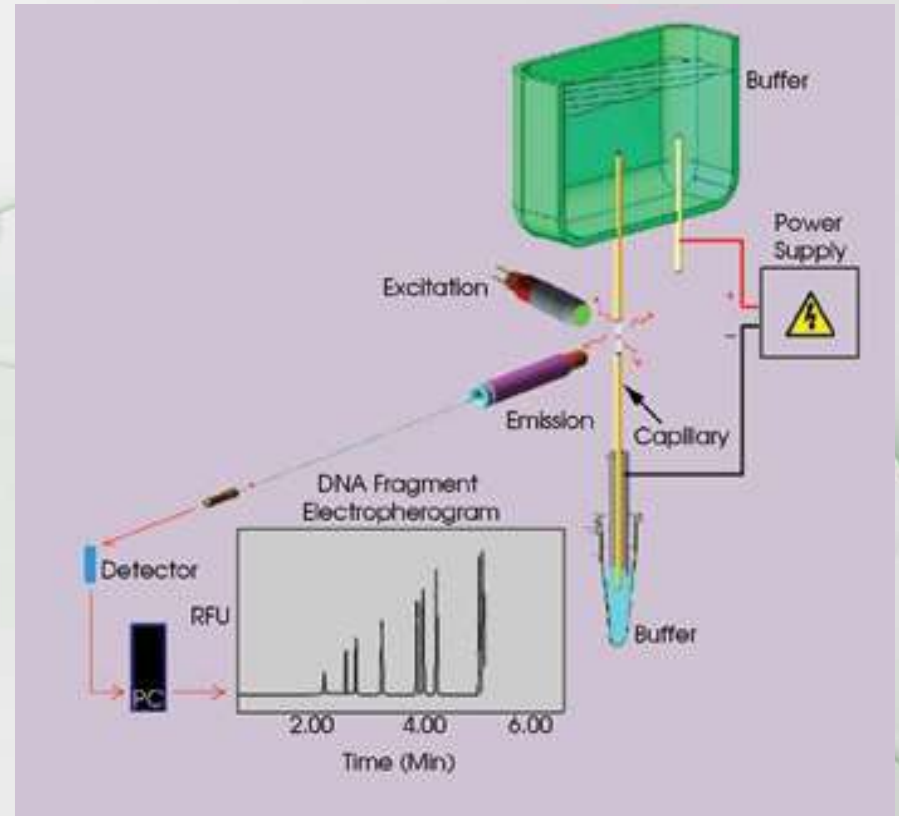
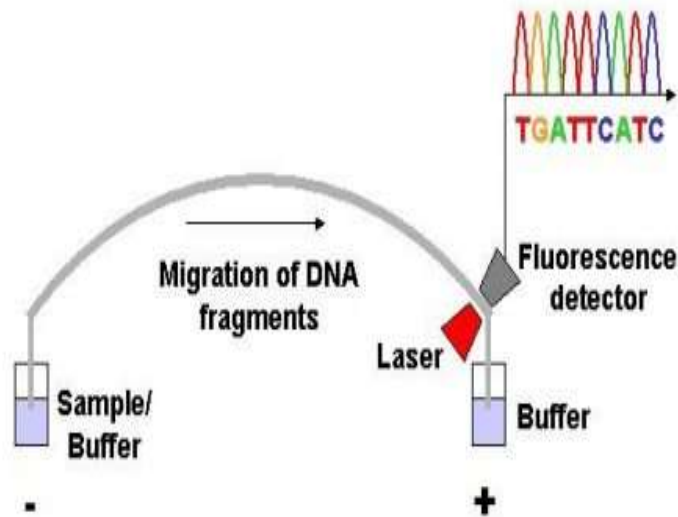

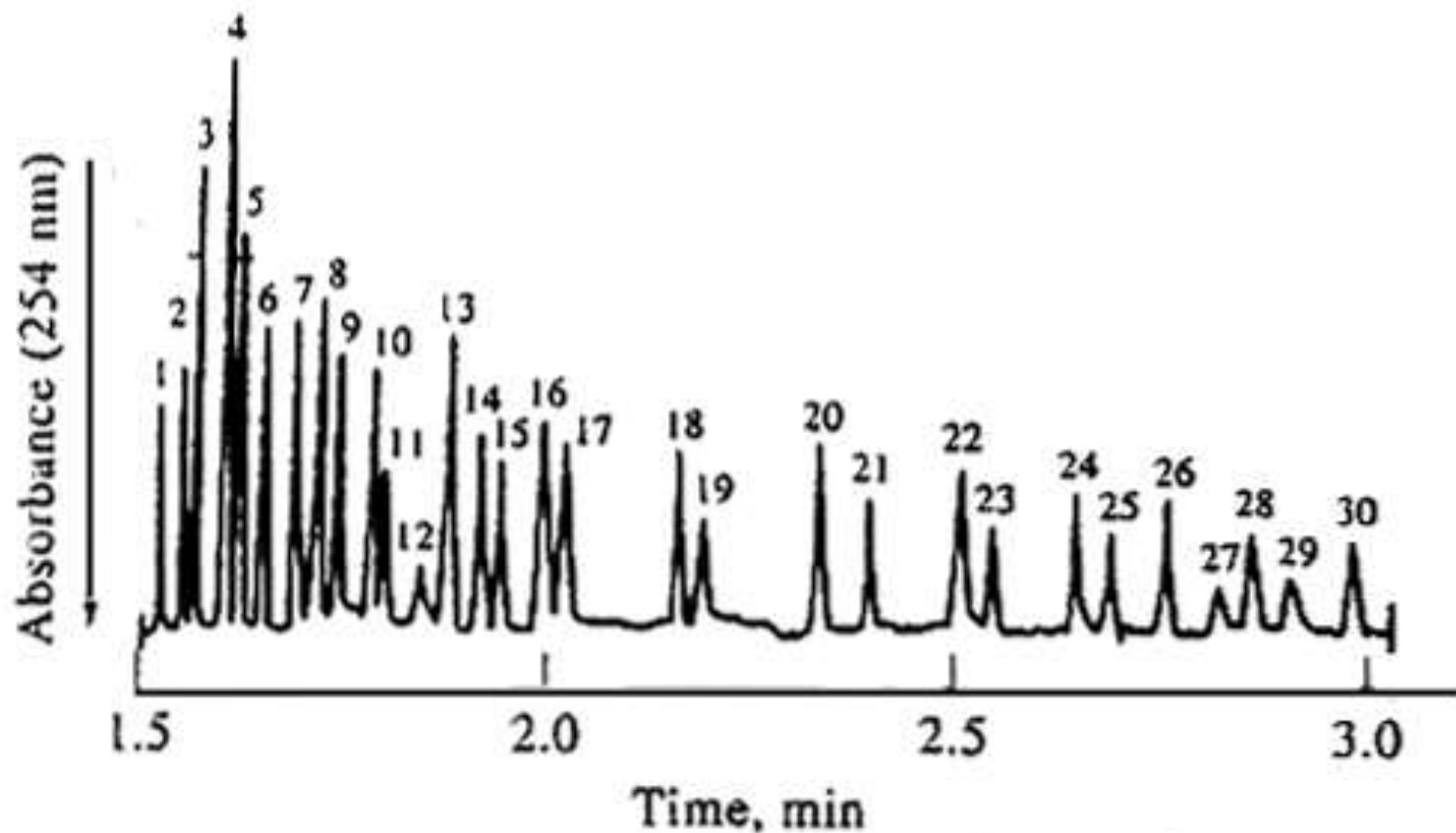

Electropherogram showing the separation of 30 anions. Capillary internal diameter: 50 μ m(fused silica). Detector: indirect UV, 254nm.

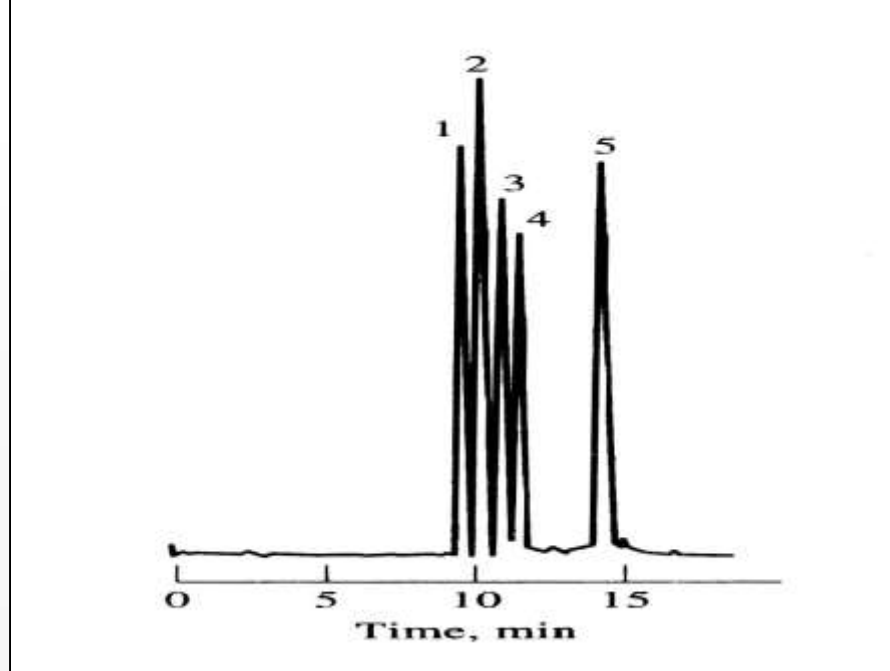

Model Proteins separated at pH 2.7

<i>Peak No.</i>	<i>Proteins</i>	<i>mol. Wt.</i>	<i>Isolelectric Point, PI</i>
1	Cytochrome c	12,400	10.7
2	Lysozyme	14,000	10.1
3	Trypsin	24,000	10.1
4	Trypsinogen	23,700	8.7
5	Trypsin inhibitor	20,100	4.5

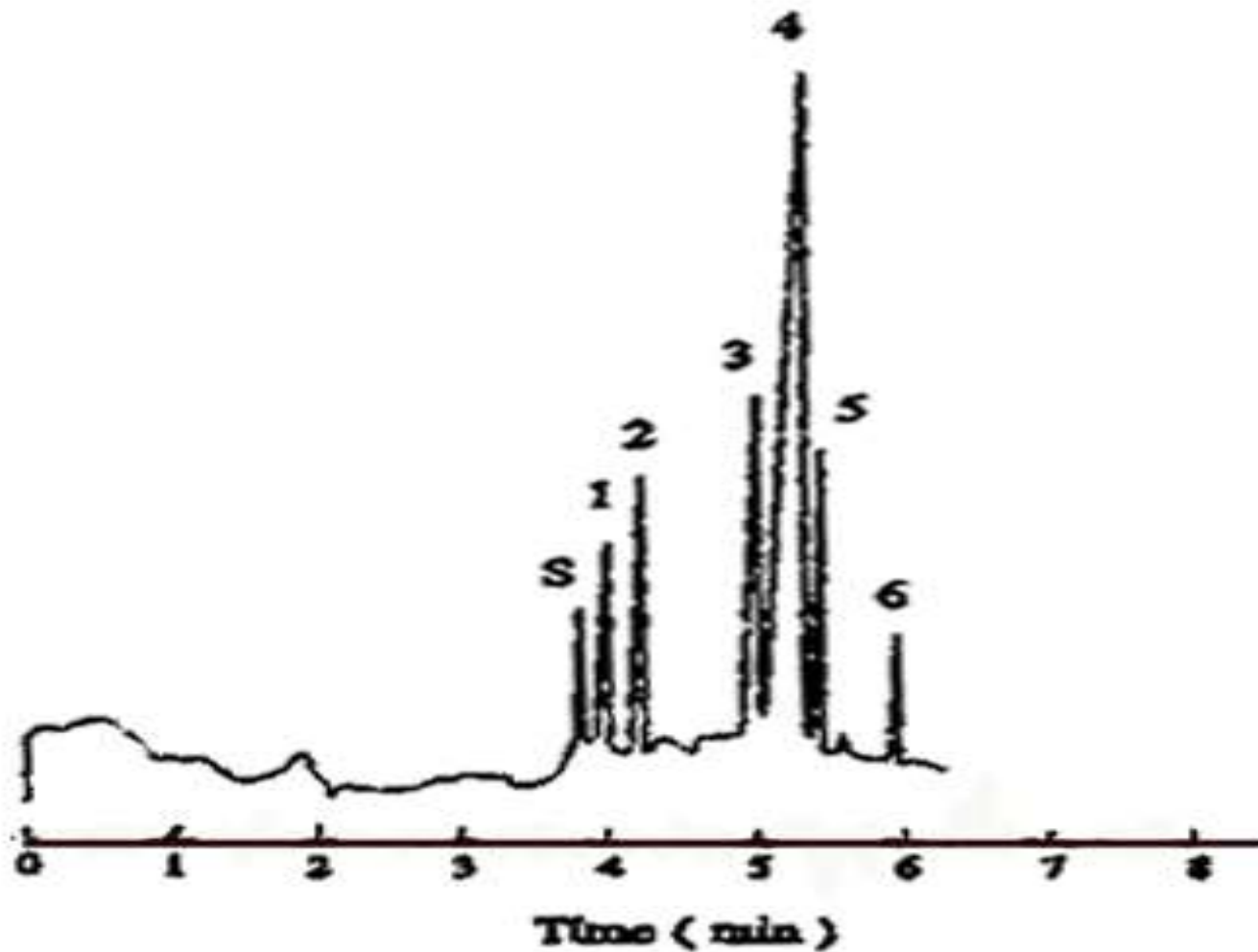

S: system peak; 1: ammonium; 2: potassium; 3: calcium; 4: sodium; 5: magnesium; 6: zinc

Conclusion:

- The capillary electrophoretic methods have been recognized: lower equipment costs, smaller sample size requirements, much greater speed, high resolution, precision, accuracy and sensitivity.
- Compared to conventional HPLC methods, the capillary electrophoresis methods have better resolution, less consumption of buffer solution and the absent organic solvents in the analysis.

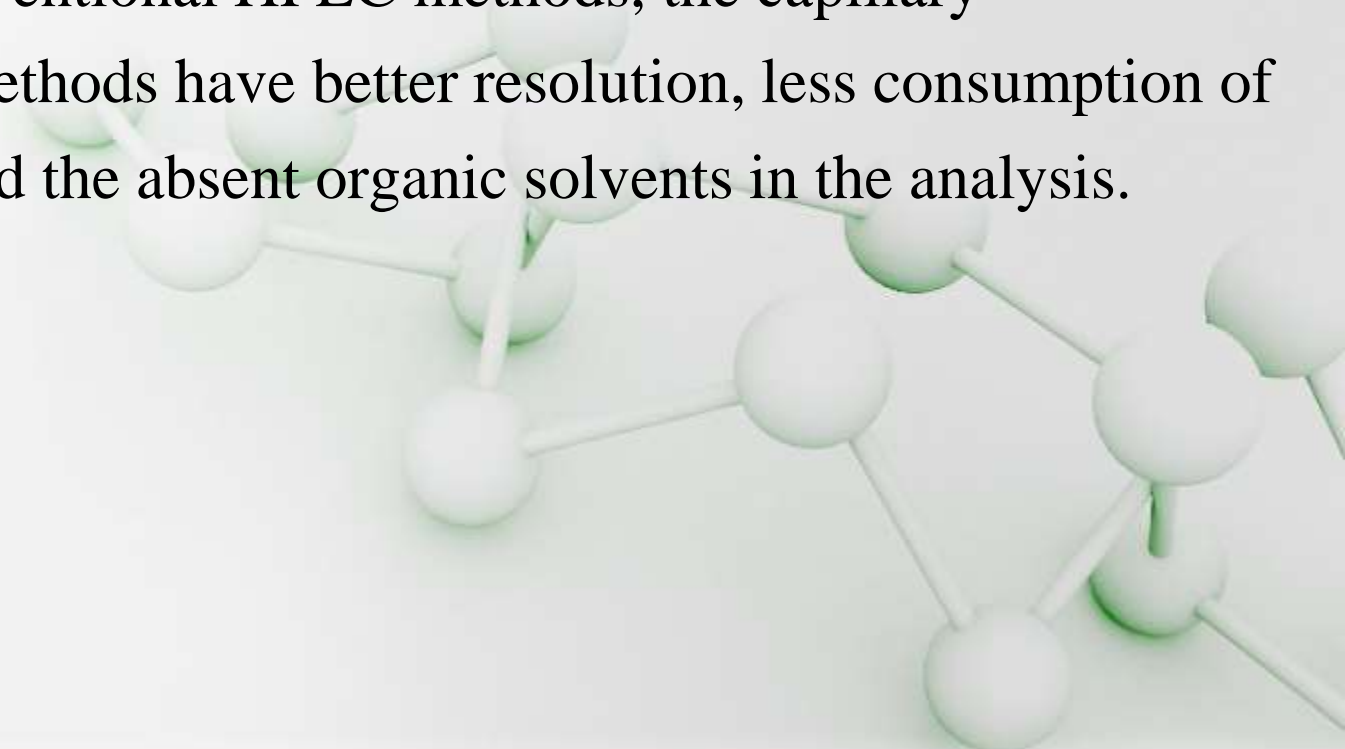

References:

1. Pharmaceutical analysis: a textbook for pharmacy students and pharmaceutical chemists, David G. Watson, pg.no:333-353.
2. Principles of instrumental analysis, 5th edition ,Skoog. Holler.Nieman
pg no:779-795.
3. en.wikipedia.org
4. www.ncbi.nlm.nih.gov
5. www.scribd.com

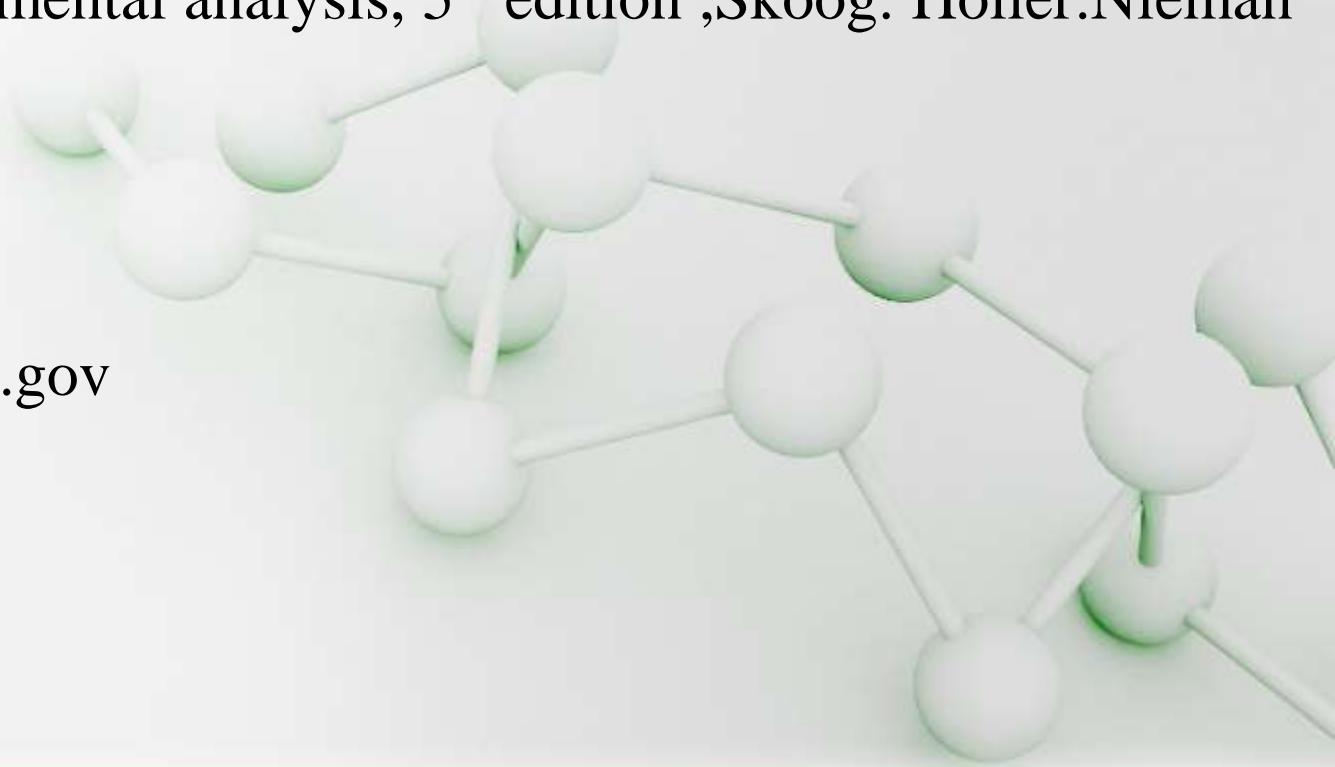

A wooden easel with a white canvas stands in a vibrant green field. The canvas displays the text "Thank u" in a bold, green, serif font. In the background, a large, leafy green tree stands against a clear blue sky. The scene is bright and cheerful, suggesting an outdoor setting.

Thank u